

JEE Main - 2018 (CBT)
Exam Test Date: 16/04/2018

Part - A (Physics)

1. The relative uncertainty in the period of a satellite orbiting around the earth is 10^{-2} . If the relative uncertainty in the radius of the orbit is negligible the relative uncertainty in the mass of the earth is :

- (1) 2×10^{-2} (2) 6×10^{-2} (3) 3×10^{-2} (4) 10^{-2}

Ans. (1)

Sol. From kepler's Law

$$T^2 = \frac{4\pi^2}{GM} r^3$$

$$\left| \frac{\Delta M}{M} \right| = 2 \frac{\Delta T}{T} = 2 \times 10^{-2}$$

2. At some instant a radioactive sample S_1 having an activity $5 \mu\text{Ci}$ has twice the number of nuclei as another sample S_2 which has an activity of $10 \mu\text{Ci}$. The half lives of S_1 and S_2 are :

- (1) 5 years and 20 years, respectively (2) 20 years and 5 years, respectively
(3) 20 years and 10 years, respectively (4) 10 years and 20 years, respectively

Ans. (1)

Sol. Given : $N_1 = 2N_2$

$$\lambda_1 N_1 = \frac{\ln 2}{t_1} \times N_1 = 5 \mu\text{Ci}$$

$$\lambda_2 N_2 = \frac{\ln 2}{t_2} \times N_2 = 10 \mu\text{Ci}$$

$$\frac{t_2}{t_1} \times \frac{N_1}{N_2} = \frac{1}{2}$$

$$\frac{t_2}{t_1} = \frac{1}{4}$$

Hence 5years and 20 year

3. Two moles of helium are mixed with n moles of hydrogen. If $\frac{C_p}{C_v} = \frac{3}{2}$ for the mixture then the value of n is

- (1) 1 (2) 3 (3) 2 (4) 3/2

Ans. (3)

Sol.
$$\frac{C_p}{C_v} = \frac{f_{\text{mix}} + 2}{f_{\text{mix}}} = \frac{3}{2}$$

$$\Rightarrow f_{\text{mix}} = 4$$

$$f_{\text{mix}} = \frac{n_1 f_1 + n_2 f_2}{n_1 + n_2}$$

$$\Rightarrow \frac{4 = 2 \times 3 + n_2 \times 5}{2 + n_2} \Rightarrow n_2 = 2 \text{mole}$$

4. Unpolarized light of intensity I is incident on a system of two polarizers, A followed by B. The intensity of emergent light is $I/2$. If a third polarizer C is placed between A and B the intensity of emergent light is reduced to $I/3$. The angle between the polarizers A and C is θ , then

(1) $\cos \theta = \left(\frac{2}{3}\right)^{1/4}$ (2) $\cos \theta = \left(\frac{1}{3}\right)^{1/4}$ (3) $\cos \theta = \left(\frac{1}{3}\right)^{1/2}$ (4) $\cos \theta = \left(\frac{2}{3}\right)^{1/2}$

Ans. (1)

Sol. A and B have same alignment of transmission axis.

Lets assume c is introduced at θ angle

$$\frac{I}{2} \cos^2 \theta \times \cos^2 \theta = \frac{I}{3}$$

$$\cos^4 \theta = \frac{2}{3} \quad \Rightarrow \quad \cos \theta = \left(\frac{2}{3}\right)^{1/4}$$

5. The de-Broglie wavelength (λ_B) associated with the electron orbiting in the second excited state of hydrogen atom is related to that in the ground state (λ_G) by :

(1) $\lambda_B = 3\lambda_G$ (2) $\lambda_B = 2\lambda_G$ (3) $\lambda_B = 3\lambda_{G/3}$ (4) $\lambda_B = 3\lambda_{G/2}$

Ans. (1)

Sol. $\frac{\lambda_B}{\lambda_G} = \frac{P_a}{P_B} = \frac{mv_G}{mv_B}$

$$V \propto \frac{Z}{n} \quad \text{So} \quad \frac{\lambda_B}{\lambda_G} = \frac{n_B}{n_G} = \frac{3}{1}$$

$$\lambda_B = 3\lambda_G$$

$$\text{Length of Orbit} = n \times \lambda$$

$$\lambda = \frac{2\pi r}{n} \quad \Rightarrow \quad \lambda \propto \frac{1}{n}$$

6. In the given circuit the current through zener diode is :

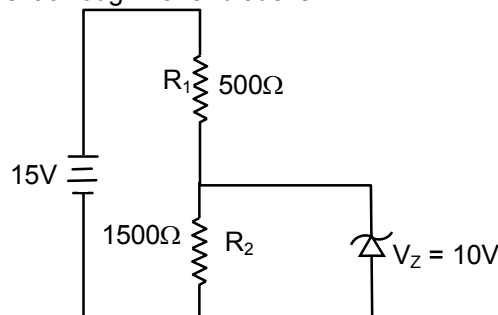

(1) 3.3mA (2) 2.5mA (3) 5.5mA (4) 6.7mA

Ans. (1)

Sol. Current in $R_1 = I_1 = \frac{5}{500}$

$$I_1 = 10 \text{ mA}$$

$$\text{Current in } R_2 = I_2 = \frac{10}{1500} \quad \Rightarrow \quad I_2 = \frac{20}{3} \text{ mA}$$

$$\text{Current in zener diode} = I_1 - I_2 = \left(10 - \frac{20}{3}\right) \text{ mA} = \frac{10}{3} \text{ mA}$$

7. The end correction of a resonance column is 1cm. If the shortest length resonating with the tuning fork is 10cm, the next resonating length should be :
 (1) 32cm (2) 40cm (3) 28cm (4) 36cm

Ans. (1)

Sol. Given : $e = 1 \text{ cm}$
 For first resonance

$$\frac{\lambda}{4} = l_1 + e = 11 \text{ cm}$$

For second resonance

$$\frac{3\lambda}{4} = l_2 + e \Rightarrow l_2 = 3 \times 11 - 1 = 32 \text{ cm}$$

8. Two sitar strings A and B playing the note 'Dha' are slightly out of tune and produce beats of frequency 5Hz. The tension of the string B is slightly increased and the beat frequency is found to decrease by 3Hz. If the frequency of A is 425 Hz. the original frequency of B is :
 (1) 428 Hz (2) 430 Hz (3) 422 Hz (4) 420 Hz

Ans. (4)

Sol. Frequency of B is either 420Hz or 430Hz As tension in B is increased its frequency will increase.
 If frequency is 430Hz, beat frequency will increase
 If frequency is 420 Hz beat frequency will decrease, hence correct answer is 420Hz

9. A power transmission line feeds input power at 2300V to a step down transformer with its primary windings having 4000 turns giving the output power at 230V. If the current in the primary of the transformer is 5A and its efficiency is 90% the output current would be :
 (1) 45A (2) 50A (3) 20A (4) 25A

Ans. (1)

Sol. Efficiency $n = 0.9 = \frac{P_s}{P_p}$

$$V_s I_s = 0.9 \times V_p I_p$$

$$I_s = \frac{0.9 \times 2300 \times 5}{230} = 45 \text{ A}$$

10. A body of mass m starts moving from rest along x-axis so that its velocity varies as $v = a\sqrt{s}$ where a is a constant and s is the distance covered by the body. The total work done by all the forces acting on the body in the first t seconds after the start of the motion is :

- (1) $8ma^4t^2$ (2) $\frac{1}{4}ma^4t^2$ (3) $4ma^4t^2$ (4) $\frac{1}{8}ma^4t^2$

Ans. (4)

Sol. $v = a\sqrt{s} = \frac{ds}{dt}$

$$2\sqrt{s} = at$$

$$s = \frac{a^2t^2}{4}$$

$$F = m \times \frac{a^2}{2}$$

$$\text{Work} = \frac{ma^2}{2} \times \frac{a^2t^2}{4} = \frac{1}{8}ma^4t^2$$

11. Suppose that the angular velocity of rotation of earth is increased. Then as a consequence:
 (1) Weight of the object every where on the earth will decrease
 (2) Weight of the object every where on the earth will increase
 (3) Except at poles weight of the object on the earth will decrease
 (4) There will be no change in weight anywhere on the earth.

Ans. (3)

Sol. $g' = g - \omega^2 R \cos^2 \phi$

Where ϕ is latitude there will be no change in gravity at poles as $\phi = 90^\circ$

At all other points as ω increases g' will decrease.

12. Both the nucleus and the atom of some element are in their respective first excited states. They get de-excited by emitting photons of wavelengths λ_N, λ_A respectively. The ratio $\frac{\lambda_N}{\lambda_A}$ is closest to :

- (1) 10^{-1} (2) 10^{-6} (3) 10 (4) 10^{-10}

Ans. (2)

Sol. $\frac{\lambda_N}{\lambda_a} = \frac{E_a}{E_N}$

where E_a and E_N are energies of photons from atom and nucleus respectively. E_N is of the order of MeV and E_a in few eV.

So $\frac{\lambda_N}{\lambda_a} = 10^{-6}$

13. A plane electromagnetic wave of wavelength λ has an intensity I . It is propagating along the positive Y-direction. The allowed expressions for the electric and magnetic fields are given by :

- | | |
|---|--|
| (1) $\vec{E} = \sqrt{\frac{2I}{\epsilon_0 c}} \cos\left[\frac{2\pi}{\lambda}(y - ct)\right] \hat{k};$ | (2) $\vec{E} = \sqrt{\frac{I}{\epsilon_0 c}} \cos\left[\frac{2\pi}{\lambda}(y - ct)\right] \hat{k};$ |
| $\vec{B} = +\frac{1}{c} E \hat{i}$ | $\vec{B} = +\frac{1}{c} E \hat{i}$ |
| (3) $\vec{E} = \sqrt{\frac{2I}{\epsilon_0 c}} \cos\left[\frac{2\pi}{\lambda}(y - ct)\right] \hat{k};$ | (4) $\vec{E} = \sqrt{\frac{I}{\epsilon_0 c}} \cos\left[\frac{2\pi}{\lambda}(y - ct)\right] \hat{i};$ |
| $\vec{B} = \frac{1}{c} E \hat{i}$ | $\vec{B} = \frac{1}{c} E \hat{k}$ |

Ans. (1)

Sol. If E_0 is magnitude of electric field then $\frac{1}{2} \epsilon_0 E^2 \times C = I$

$$E_0 = \sqrt{\frac{2I}{C\epsilon_0}}$$

$$B_0 = \frac{E_0}{C}$$

direction of $\vec{E} \times \vec{B}$ will be along $+\hat{j}$.

14. A charge q is spread uniformly over an insulated loop of radius r . If it is rotated with an angular velocity ω with respect to normal axis then magnetic moment of the loop is :

- (1) $\frac{3}{2} q\omega r^2$ (2) $\frac{1}{2} q\omega r^2$ (3) $q\omega r^2$ (4) $\frac{4}{3} q\omega r^2$

Ans. (2)

Sol.

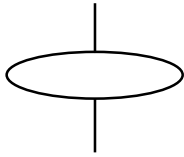

$$\frac{M}{L} = \frac{q}{2m}$$

$$M = \frac{q}{2m} \times mr^2 \omega$$

$$M = \frac{q\omega r^2}{2}$$

15. A heating element has a resistance of 100Ω at room temperature. When it is connected to a supply of $220V$ a steady current of $2A$ passes in it and temperature is $500^\circ C$ more than room temperature. What is the temperature coefficient of resistance of the heating element?

- (1) $5 \times 10^{-4} \text{ }^\circ C^{-1}$ (2) $2 \times 10^{-4} \text{ }^\circ C^{-1}$ (3) $1 \times 10^{-4} \text{ }^\circ C^{-1}$ (4) $0.5 \times 10^{-4} \text{ }^\circ C^{-1}$

Ans. (2)

Sol. Resistance after temperature increases by $500^\circ C = \frac{220}{2} = 110\Omega$

$$110 = 100 (1 + \alpha 500)$$

$$\alpha = \frac{10}{100 \times 500}$$

$$\alpha = 2 \times 10^{-4} \text{ }^\circ C^{-1}$$

16. A coil of cross-sectional area A having n turns is placed in a uniform magnetic field B . When it is rotated with an angular velocity ω the maximum e.m.f. induced in the coil will be :

- (1) $\frac{3}{2} nBA\omega$ (2) $3nBA\omega$ (3) $nBA\omega$ (4) $\frac{1}{2} nBA\omega$

Ans. (3)

Sol. $\varepsilon = BA\omega n \sin\omega t$

$$\varepsilon_{\max} = BA\omega n$$

17. A ray of light is incident at an angle of 60° on one face of a prism of angle 30° . The emergent ray of light makes an angle of 30° with incident ray. The angle made by the emergent ray with second face of prism will be :

- (1) 0° (2) 90° (3) 30° (4) 45°

Ans. (2)

Sol. $\delta = i + e - A$

$$30 = 60 + e - 30^\circ$$

$$\Rightarrow e = 0$$

So angle with face = 90°

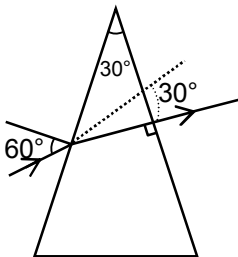

18. A galvanometer with its coil resistance 25Ω requires a current of 1mA for its full deflection. In order to construct an ammeter to read up to a current of 2A the approximate value of the shunt resistance should be :

(1) $1.25 \times 10^{-2}\Omega$ (2) $2.5 \times 10^{-3}\Omega$ (3) $2.5 \times 10^{-2}\Omega$ (4) $1.25 \times 10^{-3}\Omega$

Ans. (1)

Sol. $I_g R_g = (I - I_g)S$

$$S \approx \frac{10^{-3} \times 25}{2}$$

$$S \approx 12.5 \times 10^{-3}$$

or $1.25 \times 10^{-2}\Omega$

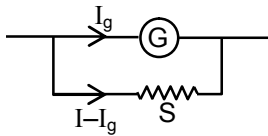

19. An oscillator of mass M is at rest in the equilibrium position in a potential $V = \frac{1}{2}k(x - X)^2$. A particle of mass m comes from right with speed u and collides completely inelastically with M and sticks to it. This process repeats every time the oscillator crosses its equilibrium position. The amplitude of oscillations after 13 collisions is : ($M = 10$, $m = 5$, $u = 1$, $k = 1$)

(1) $\frac{2}{3}$ (2) $\frac{1}{\sqrt{3}}$ (3) $\sqrt{\frac{3}{5}}$ (4) $\frac{1}{2}$

Ans. (2)

Sol. In first collision mu momentum will be imparted to system. In second collision when momentum of $(M + m)$ is in opposite direction mu momentum of particle will make its momentum zero. on 13th collision

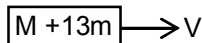

$$mu = (M + 13m)v$$

$$v = \frac{mu}{M + 13m} = \frac{u}{15}$$

$$v = \omega A$$

$$\Rightarrow \frac{u}{15} = \sqrt{\frac{K}{M + 13m}} \times A \quad \Rightarrow \quad A = \frac{1}{15} \sqrt{\frac{75}{1}} = \frac{1}{\sqrt{3}}$$

20. One mole of an ideal monatomic gas is taken along the path ABCA as shown in the PV diagram. The maximum temperature attained by the gas along the path BC is given by :

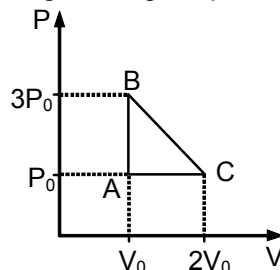

(1) $\frac{25 P_0 V_0}{4 R}$ (2) $\frac{5 P_0 V_0}{8 R}$ (3) $\frac{25 P_0 V_0}{8 R}$ (4) $\frac{25 P_0 V_0}{16 R}$

Ans. (3)

Sol. Equation of line BC

$$P = P_0 - \frac{2P_0}{V_0}(V - 2V_0)$$

$$\text{Temperature} = \frac{P_0 V - \frac{2P_0 V^2}{V_0} + 4P_0 V}{1 \times R}$$

$$T = \frac{P_0}{R} \left[5V - \frac{2V^2}{V_0} \right]$$

$$\frac{dT}{dV} = 0 \quad \Rightarrow \quad 5 - \frac{4V}{V_0} = 0 \quad \Rightarrow \quad V = \frac{5}{4} V_0$$

$$T = \frac{P_0}{R} \left[5 \times \frac{5V_0}{4} - \frac{2}{V_0} \times \frac{25}{16} V_0^2 \right]$$

$$T = \frac{25 P_0 V_0}{8 R}$$

21. In a circuit for finding the resistance of a galvanometer by half deflection method a 6V battery and a high resistance of 11kΩ are used. The figure of merit of the galvanometer produces a deflection of $\theta = 9$ divisions when current flows in the circuit. The value of the shunt resistance that can cause the deflection of $\theta/2$ is

(1) 550Ω

(2) 220Ω

(3) 55Ω

(4) 110Ω

Ans. (4)

Sol. $I = \frac{\varepsilon}{R+G}$ $G = \frac{1}{9} \text{K}\Omega$

$$\frac{I}{2} = \frac{\varepsilon}{R + \frac{GS}{G+S}} \times \frac{S}{S+G} \quad \Rightarrow \quad \frac{I}{2} = \frac{\varepsilon S}{R(S+G) + GS}$$

$$S = \frac{RG \times \frac{I}{2}}{\varepsilon - \frac{(R+G)I}{2}}$$

$$S = \frac{11 \times 10^3 \times \frac{1}{9} \times 10^3 \times 270 \times 10^{-6}}{6 - \left(\frac{6}{2}\right)}$$

$S = 110\Omega$

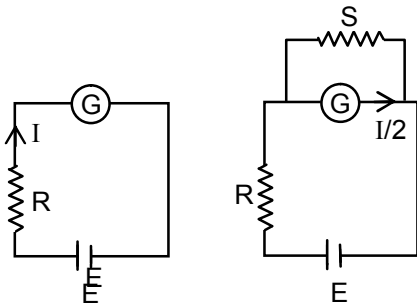

22. In the following circuit the switch S is closed at $t = 0$. The charge on the capacitor C_1 as a function of time will be given by $\left(C_{eq} = \frac{C_1 C_2}{C_1 + C_2} \right)$

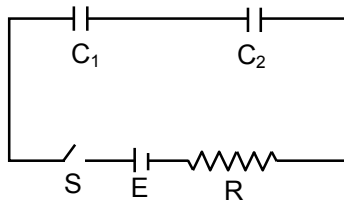

- (1) $C_1 E [1 - \exp(-tR/C_1)]$ (2) $C_{eq} E \exp(-t/RC_{eq})$
 (3) $C_{eq} E [1 - \exp(-t/RC_{eq})]$ (4) $C_2 E [1 - \exp(-t/RC_2)]$

Ans. (3)

Sol. $q = C_{eq} E [1 - e^{-t/RC_{eq}}]$

Both capacitor will have same charge as they are connected in series.

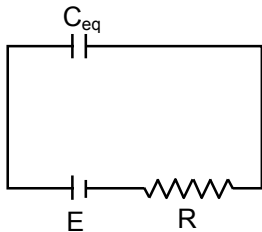

23. Let $\vec{A} = (\hat{i} + \hat{j})$ and $\vec{B} = (2\hat{i} - \hat{j})$. The magnitude of a coplanar vector \vec{C} such that $\vec{A} \cdot \vec{C} = \vec{B} \cdot \vec{C} = \vec{A} \cdot \vec{B}$ is given by :

- (1) $\sqrt{\frac{9}{12}}$ (2) $\sqrt{\frac{20}{9}}$ (3) $\sqrt{\frac{5}{9}}$ (4) $\sqrt{\frac{10}{9}}$

Ans. (3)

Sol. If $\vec{C} = a\hat{i} + b\hat{j}$ then

$$\vec{A} \cdot \vec{C} = \vec{A} \cdot \vec{B}$$

$$a + b = 1 \quad \dots(i)$$

$$\vec{B} \cdot \vec{C} = \vec{A} \cdot \vec{B}$$

$$2a - b = 1 \quad \dots(ii)$$

Solving equation (i) and (ii) we get

$$a = \frac{1}{3}, b = \frac{2}{3}$$

$$|\vec{C}| = \sqrt{\frac{1}{9} + \frac{4}{9}} = \sqrt{\frac{5}{9}}$$

24. A particle executes simple harmonic motion and is located at $x = a, b$ and c at times $t_0, 2t_0$ and $3t_0$ respectively. The frequency of the oscillation is :

- (1) $\frac{1}{2\pi t_0} \cos^{-1}\left(\frac{a+c}{2b}\right)$ (2) $\frac{1}{2\pi t_0} \cos^{-1}\left(\frac{a+2b}{3c}\right)$ (3) $\frac{1}{2\pi t_0} \cos^{-1}\left(\frac{a+b}{2c}\right)$ (4) $\frac{1}{2\pi t_0} \cos^{-1}\left(\frac{2a+3c}{b}\right)$

Ans. (1)

Sol. $a = A\sin\omega t_0$
 $b = A\sin 2\omega t_0$
 $c = A\sin 3\omega t_0$
 $a + c = A[\sin\omega t_0 + \sin 3\omega t_0] = 2A\sin 2\omega t_0 \cos\omega t_0$

$$\frac{a+c}{b} = 2\cos\omega t_0$$

$$\omega = \frac{1}{t_0} \cos^{-1}\left(\frac{a+c}{2b}\right) \Rightarrow f = \frac{1}{2\pi t_0} \cos^{-1}\left(\frac{a+c}{2b}\right)$$

25. A thin circular disk is in the xy plane as shown in the figure. The ratio of its moment of inertia about z and z' axes will be :

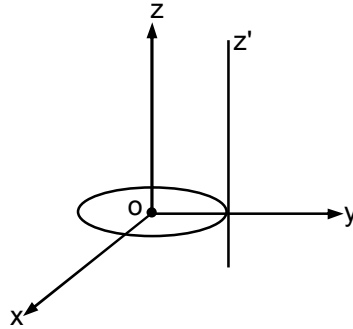

- Ans.** (1) 1 : 4 (2) 1 : 5 (3) 1 : 3 (4) 1 : 2
(3)

Sol. $I_z = \frac{mR^2}{2}$

$$I_{z'} = \frac{3}{2} mR^2 \frac{I_z}{I_z} = \frac{1}{3}$$

26. Two identical conducting spheres A and B carry equal charge. They are separated by a distance much larger than their diameters and the force between them is F. A third identical conducting sphere C is uncharged. Sphere C is first touched to A then to B and then removed. As a result the force between A and B would be equal to :

- (1) $\frac{3F}{4}$ (2) $\frac{F}{2}$ (3) $\frac{3F}{8}$ (4) F
Ans. (3)

Sol.



$$F = \frac{kq^2}{r^2} \text{ when A and C are touched charge on both will be } \frac{q}{2}$$

Then when B and C are touched

$$q_B = \frac{\frac{q}{2} + q}{2} = \frac{3q}{4}$$

$$F' = \frac{kq_A q_B}{r^2} = \frac{k \times \frac{q}{2} \times \frac{3q}{4}}{r^2} = \frac{3kq^2}{8r^2} = \frac{3}{8} F$$

27. Two particles of the same mass m are moving in circular orbits because of force given by $F(r) = \frac{-16}{r} - r^3$. The first particle is at distance $r = 1$ and the second at $r = 4$. The best estimate for the ratio of kinetic energies of the first and the second particle is closest to :

(1) 3×10^{-3} (2) 6×10^2 (3) 6×10^{-2} (4) 10^{-1}

Ans. (3)

Sol.
$$\frac{mV^2}{r} = \frac{16}{r} + r^3$$

$$KE_0 = \frac{1}{2} mV^2$$

$$= \frac{1}{2} [16 + r^4]$$

$$\frac{K_1}{K_2} = \frac{\frac{16+1}{2}}{\frac{16+256}{2}} = \frac{17}{272}$$

$$\frac{K_1}{K_2} \approx 6 \times 10^{-2}$$

28. The percentage errors in quantities P, Q, R and S are 0.5%, 1%, 3% and 1.5% respectively in the measurement of a physical quantity $A = \frac{P^3Q^2}{\sqrt{RS}}$. The maximum percentage error in the value of A will be :

(1) 6.5% (2) 7.5% (3) 6.0% (4) 8.5%

Ans. (1)

Sol.
$$\frac{\Delta A}{A} = \frac{3\Delta P}{P} + \frac{2\Delta Q}{Q} + \frac{1}{2} \frac{\Delta R}{R} + \frac{\Delta S}{S}$$

$$= 3 \times 0.5 + 2 \times 1 + \frac{1}{2} \times 3 + 1.5$$

$$= 1.5 + 2 + 1.5 + 1.5$$

$$\frac{\Delta A}{A} = 6.5\%$$

29. A carrier wave of peak voltage 14V is used for transmitting a message signal given to achieve a modulation index of 80% will be :

(1) 22.4V (2) 7V (3) 11.2V (4) 28V

Ans. (3)

Sol.
$$m = \frac{A_m}{A_c}$$

$$A_m = 0.8 \times 14$$

$$= 11.2V$$

30. A small soap bubble of radius 4cm is trapped inside another bubble of radius 6cm without any contact. Let P_2 be the pressure inside the inner bubble and P_0 the pressure outside the outer bubble. Radius of another bubble with pressure difference $P_2 - P_0$ between its inside and outside would be :

(1) 2.4cm (2) 12cm (3) 4.8cm (4) 6cm

Ans. (1)

Sol. $P_2 = P_0 + \frac{4T}{6} + \frac{4T}{4}$
 $\Rightarrow \frac{1}{r} = \frac{1}{6} + \frac{1}{4}$

$P_2 = P_0 + \frac{4T}{r}$
 $\Rightarrow r = 2.4\text{cm}$

