

# Physics (Abroad) Question Paper 2019 (Set-3)

---

## General Instructions:

1. All questions are compulsory. There are 27 questions in all.
2. This question paper has four sections: Section A, Section B, Section C and Section D.
3. Section A contains five questions of one mark each, Section B contains seven questions of two marks each, Section C contains twelve questions of three marks each, and Section D contains three questions of five marks each.
4. There is no overall choice. However, internal choices have been provided in two questions of one mark, two questions of two marks, four questions of three marks and three questions of five marks weightage. You have to attempt only one of the choices in such questions.

5. You may use the following values of physical constants wherever necessary.

$$c = 3 \times 10^8 \text{ m/s}$$

$$h = 6.63 \times 10^{-34} \text{ Js}$$

$$e = 1.6 \times 10^{-19} \text{ C}$$

$$\mu_0 = 4\pi \times 10^{-7} \text{ T m A}^{-1}$$

$$\epsilon_0 = 8.854 \times 10^{-12} \text{ C}^2 \text{ N}^{-1} \text{ m}^{-2}$$

$$\frac{1}{4\pi\epsilon_0} = 9 \times 10^9 \text{ N m}^2 \text{ C}^{-2}$$

$$m_e = 9.1 \times 10^{-31} \text{ kg}$$

$$\text{mass of neutron} = 1.675 \times 10^{-27} \text{ kg}$$

$$\text{mass of proton} = 1.673 \times 10^{-27} \text{ kg}$$

$$\text{Avogadro's number} = 6.023 \times 10^{23} \text{ per gram mole}$$

$$\text{Boltzmann constant} = 1.38 \times 10^{-23} \text{ JK}^{-1}$$

---

**Q.1. Plot a graph of stopping potential ( $V_0$ ) versus the frequency ( $\nu$ ) of incident radiation in photoelectric emission.**

**Solution:**

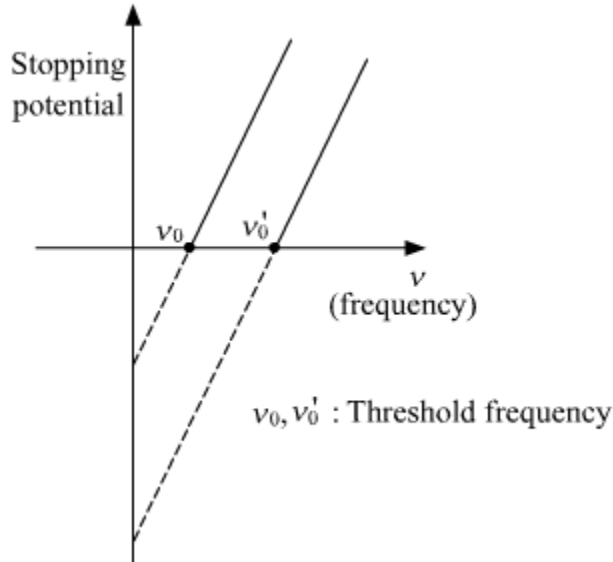

**Q.2 Name the charge carries for the flow of current in a (i) conductor and (ii) electrolyte.**

**Solution:** Charge carries for the flow of current in:

- (i) Conductor:- Electrons
- (ii) Electrolyte:- Ions.

**Q.3. Why are the antennas in space wave mode of propagation generally mounted at heights of many wavelengths above the ground ?**

**Solution.** The antennas in space wave mode of propagation generally mounted at the height of many wavelengths in order to prevent waves from touching the earth curvature thus preventing attenuation and loss of signal strength.

**Q.4. Two identical conducting balls A and B have charges  $-Q$  and  $+3Q$  respectively. They are brought in contact with each other and then separated by a distance  $d$  apart. Find the nature of the Coulomb force between them.**

**OR**

**A metallic spherical shell has an inner radius  $R_1$  and outer radius  $R_2$ . A charge  $Q$  is placed at the center of the shell. What will be the surface charge density on the (i) inner surface, and (ii) outer surface of the shell?**

**Solution:**

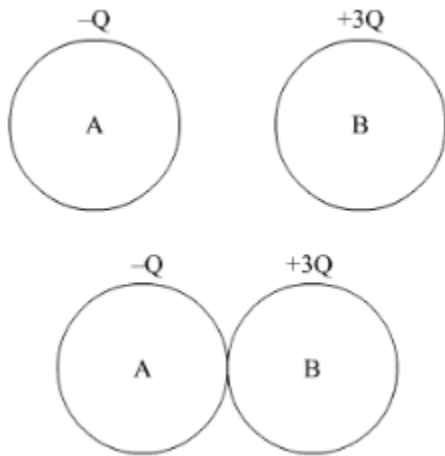

After the contact charge will redistribute equally on both the balls, the new charges on both conducting balls are:

$$Q_A = \frac{-Q+3Q}{2} = Q$$

$$Q_B = \frac{-Q+3Q}{2} = Q$$

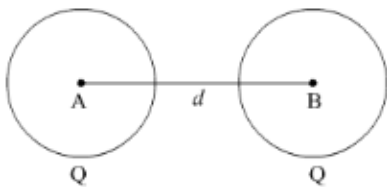

According to C olumb law,

$$F = \frac{KQ_1Q_2}{R^2}$$

$$F_{AB} = \frac{KQ_AQ_B}{d^2} = \frac{KQ^2}{d^2}$$

$$\Rightarrow F_{AB} = \frac{KQ^2}{d^2}$$

**OR**

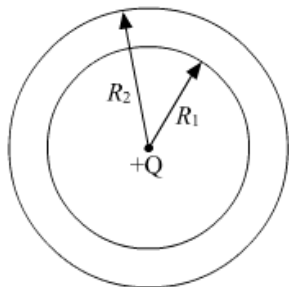

Because of the induction, the inner surface will occupy a negative charge '-Q' and the outer surface will occupy a positive charge '+Q'.

As the spherical shell has an inner radius  $R_1$  and outer radius  $R_2$ ,

$$\text{Charge density (inner)} = \frac{-Q}{4\pi R_1^2}$$

$$\text{Charge density (outer)} = \frac{+Q}{4\pi R_2^2}$$

**Q.5. The small ozone layer on top of the stratosphere is crucial for human survival. Why ?**

**OR**

**Illustrate by giving suitable examples, how you can show that electromagnetic waves carry energy and momentum.**

**Solution:** The small ozone layer on the top of the atmosphere is crucial for human survival because it absorbs harmful ultraviolet radiation present in sunlight and prevents it from reaching the earth's surface

**OR**

Electromagnetic waves carry energy and momentum across space.

If we put an electric charge on a plane perpendicular to the direction of propagation of EM wave, it will set into motion due to the electric and magnetic force carried by the wave. This illustrates the EM wave carry Energy in the form of electric and magnetic energy.

The energy carried by an electromagnetic wave is inversely proportional to its wavelength,

$$E = \frac{hc}{\lambda}$$

Electromagnetic waves carry momentum, it can be proved by the fact that electromagnetic waves exert a force on the surface on which they are incident, because they deliver their momentum to the surface they fall on.

The momentum carried by an electromagnetic wave is proportional to its energy,

$$p = \frac{E}{c}$$

**Q.6. Two long straight wires carrying currents of 2 A and 5 A in the same direction are kept parallel, 10 cm apart from each other. Calculate the force acting between them and write its nature.**

**Solution:**

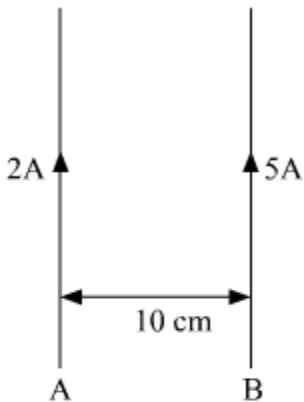

Magnetic field by A at the position of B will be

$$= \frac{\mu_0 I_A}{2\pi d} = \frac{\mu_0 \times 2}{2\pi \times 10 \times 10^{-2}} = \frac{10\mu_0}{\pi} \text{ T}$$

Force per unit length on wire B =  $B I_B$

$$= \frac{10\mu_0}{\pi} \times 5$$

$$= \frac{50\mu_0}{\pi}$$

The magnitude of force per unit length on B =  $\frac{50\mu_0}{\pi}$

The direction of the magnetic field on the position of wire B is into the plane of the paper.

As per Right-hand thumb rule, Force on B is towards wire A.

Hence net force between the wire is  $\frac{50\mu_0}{\pi}$ , which is attractive in nature.

**Q.7. A parallel plate capacitor of plate area  $A$  each and separation  $d$ , is being charged by an AC source. Show that the displacement current inside the capacitor is the same as the current charging the capacitor.**

**Solution.** Displacement current or Maxwell's displacement current is the current produced inside the capacitor due to change in electric flux in the region between the plates.

The displacement current is given by,

$$i_D = \epsilon_0 \frac{d\phi_E}{dt} \dots (1)$$

Where  $\phi_E$  is the electric flux and  $E$  is the electric field.

As the charge  $Q$  on the capacitor plates changes with time, there is a current which is charging the capacitor

$$i = \frac{dQ}{dt} \dots (2)$$

$$\because \phi_E = EA \quad (A \text{ is the area of plates})$$

$$i_D = \epsilon_0 \frac{d\phi_E}{dt} = \epsilon_0 \frac{d(EA)}{dt}$$

$$\because E = \frac{V}{d}$$

$$\therefore i_D = \frac{\epsilon_0 A}{d} \frac{d(V)}{dt} = C \frac{d(V)}{dt} \quad (C \text{ is the capacitance})$$

$$\Rightarrow i_D = \frac{d(CV)}{dt} \quad (\because CV = Q)$$

$$\Rightarrow i_D = \frac{d(Q)}{dt} \dots \dots (3)$$

From equation 2 and 3, we can conclude,

$$\Rightarrow i_D = \frac{d(Q)}{dt} = i \quad (\text{where 'i' is Current charging the capacitor})$$

**Q.8. Apply Gauss's law to show that for charged spherical shell, the electric field outside the shell is, as if the entire charge were concentrated at the centre.**

OR

**Two large parallel plane sheets have uniform charge densities  $+\sigma$  and  $-\sigma$ . Determine the electric field (i) between the sheets, and (ii) outside the sheets.**

**Solution:** Electric Field Due to a Uniformly Charged Thin Spherical Shell when point P lies outside the spherical shell

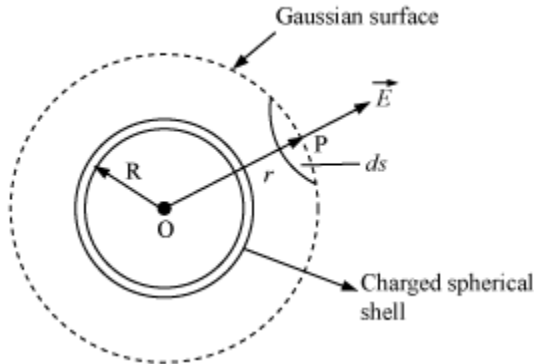

Suppose, we have to calculate the electric field at the point  $P$  at a distance  $r$  ( $r > R$ ) from its center. A Gaussian surface is drawn through point  $P$  to enclose the charged spherical shell. The Gaussian surface is a spherical shell of radius  $r$  and center  $O$ .

Let  $\vec{E}$  be the electric field at point  $P$ . Then, the electric flux through area element  $\vec{ds}$ ,

$$d\phi = \vec{E} \cdot \vec{ds}$$

Since  $\vec{ds}$  is also along the normal to the surface,

$$d\phi = E ds$$

$\therefore$  Total electric flux through the Gaussian surface,

$$\phi = \oint_S E ds = E \oint_S ds$$

Now,

$$\oint dS = 4\pi r^2$$

$$\therefore \phi = E \times 4\pi r^2 \quad \dots(i)$$

Since the charge enclosed by the Gaussian surface is  $q$ , according to Gauss' Theorem,

$$\phi = \frac{q}{\epsilon_0} \quad \dots(ii)$$

From equations (i) and (ii), we get:

$$E \times 4\pi r^2 = \frac{q}{\epsilon_0}$$

$$E = \frac{1}{4\pi\epsilon_0} \cdot \frac{q}{r^2} \quad (\text{ for } r > R)$$

Now, if we consider that entire charge is concentrated at the center, the electric field at point  $P$  will be given by expression,

$$E = \frac{1}{4\pi\epsilon_0} \frac{q}{r^2}$$

Thus the Expression in equation 3, is the same as the calculated electric field as if the charge is concentrated at the center i.e. due to a point charge at the center of the shell in equation 4.

OR

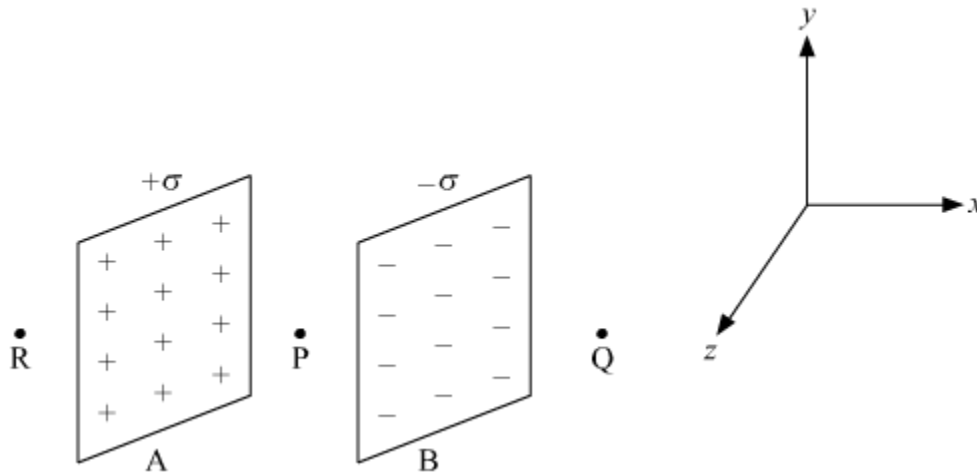

Let  $P$  is the point between the plates A and B, and  $Q$  and  $R$  are the points outside the plates.

$$\vec{E}_P = \vec{E}_A \left( \text{Due to A} \right) + \vec{E}_B \left( \text{Due to B} \right)$$

$$\vec{E}_P = \frac{\sigma}{2\epsilon_0} \left( \text{towards +ve x-axis} \right) + \frac{\sigma}{2\epsilon_0} \left( \text{towards +ve x-axis} \right)$$

$$= \frac{2\sigma}{2\epsilon_0} = \frac{\sigma}{\epsilon_0} \left( \text{towards +ve x-axis} \right)$$

$$\vec{E}_P = \frac{\sigma}{\epsilon_0} \left( \text{towards +ve x-axis} \right)$$

$$\vec{E}_Q = \vec{E}_Q \left( \text{due to A} \right) + \vec{E}_Q \left( \text{due to B} \right)$$

$$= \frac{\sigma}{2\epsilon_0} \left( \text{towards +ve x-axis} \right) + \frac{\sigma}{2\epsilon_0} \left( \text{towards -ve x-axis} \right)$$



$$\Rightarrow \vec{E}_Q = 0$$

Similarly,  $\vec{E}_R = 0$

Hence, Electric-field between the sheets is  $\sigma/\epsilon_0$  towards the sheet carrying the negative charge (i.e towards +ve x-axis) & the field outside the sheets is zero.

**Q.9. Out of the two optical instruments, a microscope and a telescope, which one plays the role in magnifying the objects and in resolving the two objects kept close to each other? Explain, giving example.**

**Solution.** A microscope is an optical instrument, used for magnifying the objects. It is a convex lens having a short focal length which enables us to view very small objects because of its high magnifying power. Example: microscope used in laboratories, to magnify and view microorganisms.

However, a telescope is used for resolving two objects kept close to each other eg: pair of stars. The objective lens of the telescope has a long focal length which enables us to view far objects. Example: resolving a pair of stars through a telescope, stars which appear very close to each other as they are very far away. A telescope helps to resolve them, hence we are able to see discrete stars through a telescope.

**Q.10. A beam of light converges at a point  $P$ . Now a convex lens is placed in the path of the convergent beam at 15 cm from  $P$ . At what point does a beam converge if the convex lens has a focal length 10 cm?**

OR

**An object is kept in front of a concave mirror of focal length 15 cm. The image formed is real and three times the size of the object. Calculate the distance of the object from the mirror.**

**Solution:**

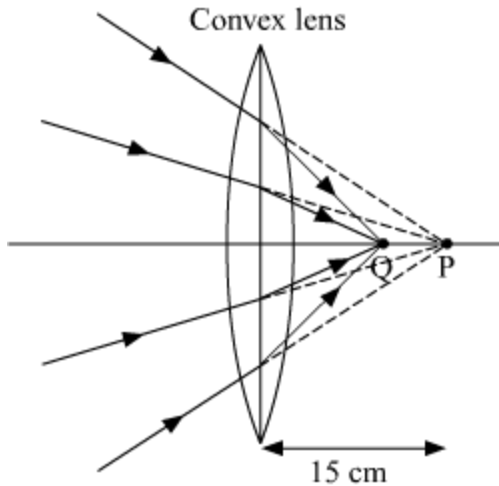

Here the object is a vertical object at  $P$ .  
 According to sign convention,  
 Object distance =  $u = +15$  cm  
 Focal length =  $f = +10$  cm

Using lens formula,

$$\frac{1}{v} - \frac{1}{u} = \frac{1}{f}$$

$$\frac{1}{v} - \frac{1}{15} = \frac{1}{10}$$

$$\frac{1}{v} = \frac{1}{10} + \frac{1}{15} = \frac{3+2}{30} = \frac{5}{30}$$

$$v = \frac{30}{5} = +6 \text{ cm}$$

Hence the beam converges at 6 cm from the lens on the side of point P.

**OR**

As the image formed is real, so it will be inverted. Hence magnification of the mirror,

$$m = -\frac{v}{u} = \frac{h_i}{h_o} = -3$$

$$\Rightarrow -\frac{v}{u} = -3$$

$$\Rightarrow v = +3u$$

Using mirror formula,  $\frac{1}{v} + \frac{1}{u} = \frac{1}{f}$

$$\Rightarrow \frac{1}{+3u} + \frac{1}{u} = \frac{1}{f}$$

$$\Rightarrow \frac{1+3}{3u} = \frac{1}{f}$$

$$\Rightarrow \frac{4}{3u} = \frac{1}{f} \Rightarrow u = \frac{4f}{3}$$

$$u = \frac{4 \times (-15)}{3} \left( \because f = -15 \text{ cm} \right)$$

$$\therefore u = -20 \text{ cm}$$

Hence the object distance = - 20 cm. Hence the object is placed at a distance of 20 cm in front of the mirror.

**Q.11. For a CE transistor amplifier, the audio signal voltage across the collector resistance of 2 k $\Omega$  is 2 V. If the current amplification factor of the transistor is 100, calculate the input signal voltage and the base current, given the base resistance as 1 k $\Omega$ .**

**Solution:**  $R_0 = 2 \text{ K}\Omega$

$$V_0 = 2 \text{ V}$$

Current amplification,  $A_i = 100$

Input signal voltage,  $V_i = ?$

Base current,  $I_b = ?$

$$R_B = 1 \text{ K}\Omega$$

$$V_0 = I_c R_0 = 2 \text{ V}$$

$$I_c = \frac{2}{R_0} = \frac{2}{2 \times 10^3} = 10^{-3} \text{ A}$$

$$I_c = 1 \text{ mA}$$

$$A_i = \frac{I_c}{I_B}$$

$$100 = \frac{10^{-3}}{I_B}$$

$$I_B = \frac{10^{-3}}{100} = 10^{-3} \times 10^{-2} \text{ A}$$

$$I_B = 10 \mu\text{A}$$

$$V_i = I_B R_B = 10 \times 10^{-6} \times 10^3 \text{ V}$$

$$V_i = 10^{-2} \text{ V}$$

Q.12.

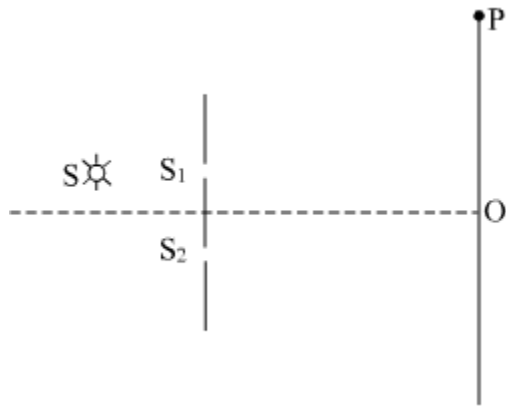

The figure shows a modified Young's double slit experimental set-up. Here  $SS_2 - SS_1 = \lambda/4$ .

- (a) Write the condition for constructive interference.  
 (b) Obtain an expression for the fringe width.

**Solution:** (a)  $SS_2 - SS_1 = \lambda/4$

Condition for constructive interference,

$$n\lambda = (SS_2 - SS_1) + (S_2P - S_1P)$$

$$n\lambda = \frac{\lambda}{4} + \Delta x$$

$$\Delta x = \left( n\lambda - \frac{\lambda}{4} \right)$$

$$\Delta x = \lambda \left( n - \frac{1}{4} \right)$$

(b) From YDSE.

$\Delta x$  (Path difference) at  $P$  point is,  $\Delta x = \frac{yd}{D}$

$$\text{Now, } \lambda \left( n - \frac{1}{4} \right) = \frac{yd}{D}$$

$$n = 1 \quad \lambda \left( 1 - \frac{1}{4} \right) = \frac{y_1 d}{D}$$

$$\frac{3\lambda}{4} = \frac{y_1 d}{D}$$

$$y_1 = \frac{3\lambda D}{4d}$$

$$n = 2, \quad \lambda \left( 2 - \frac{1}{4} \right) = \frac{y_2 d}{D}$$

$$\lambda \left( \frac{7}{4} \right) = \frac{y_2 d}{D}$$

$$y_2 = \frac{7\lambda D}{4d}$$

Fringe width,  $\beta = y_2 - y_1$

$$\beta = \frac{7}{4} \frac{\lambda D}{d} - \frac{3}{4} \frac{\lambda D}{d}$$

$$\beta = \frac{\lambda D}{d}$$

**Q.13.** Use Bohr's postulates to derive the expressions for the potential and kinetic energy of the electron moving in the  $n^{\text{th}}$  orbit of the hydrogen atom. How is the total energy of the electron expressed in terms of its kinetic and potential energies?

**Solution:**

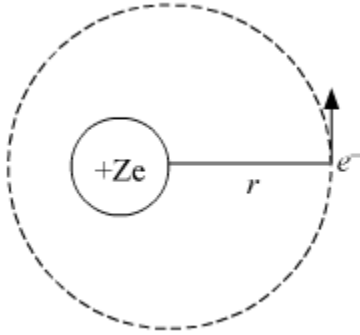

$$F = \frac{K(Ze)(e)}{r^2}$$

$$F_e = \frac{KZe^2}{r^2}$$

$$F_e = \frac{mv^2}{r}$$

$$\frac{KZe^2}{r^2} = \frac{mv^2}{r}$$

$$mv^2 = \frac{KZe^2}{r}$$

$$\frac{1}{2} (mv^2) = \frac{1}{2} \left( \frac{KZe^2}{r} \right)$$

$$KE = \frac{KZe^2}{2r}$$

Potential energy

$$U = \frac{K(Ze)(-e)}{r}$$

$$U = \frac{-KZe^2}{r}$$

$$KE = \frac{KZe^2}{2r} \dots\dots\dots (i)$$

$$U = -\frac{KZe^2}{r} \dots\dots\dots (ii)$$

$$E = KE + U$$

$$E = \frac{KZe^2}{2r} - \frac{KZe^2}{r}$$

$$= \frac{KZe^2 - 2KZe^2}{2r}$$

$$E = -\frac{KZe^2}{2r} \dots \dots \dots (iii)$$

From (i), (ii) and (iii)

$$|E| = |KE| = \left| \frac{U}{2} \right|$$

$$\text{now, } \frac{KZe^2}{r^2} = \frac{mv^2}{r}$$

$$mv^2 = \frac{KZe^2}{r} \dots \dots \dots (iv)$$

$$mvr = \frac{nh}{2\pi}$$

$$v = \frac{nh}{2\pi mr}$$

Put  $v$  in upon (iv)

$$m \left( \frac{nh}{2\pi mr} \right)^2 = \frac{KZe^2}{r}$$

$$\frac{mn^2h^2}{4\pi^2m^2r^2} = \frac{KZe^2}{r}$$

$$\frac{n^2h^2}{4\pi^2mr} = KZe^2$$

From equation (i) and (ii) and (iii), we can also conclude that, Total energy,  $E = U/2 = -$  K.E.

**Q.14. (a) Depict the magnetic field lines due to a circular current carrying loop showing the direction of field lines.**

**(b) A current  $I$  is flowing in a conductor placed along the x-axis as shown in the figure. Find the magnitude and direction of the magnetic field due to a small current**

**element  $\vec{dl}$  lying at the origin at points (i)  $(0,d,0)$  and (ii)  $(0,0,d)$ .**

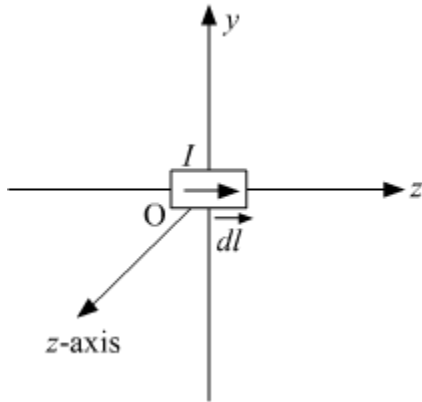

**Solution:**

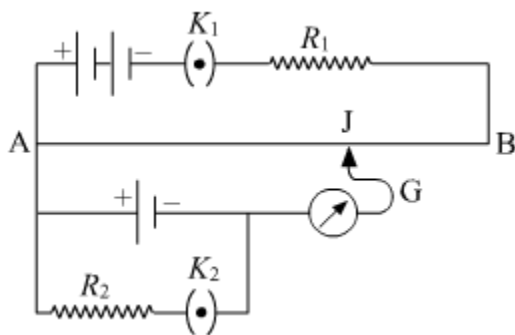

(a) For the circuit shown in the figure, how would the balancing length be affected, if

(i)  $R_1$  is decreased

(ii)  $R_2$  is increased

the other factors remaining the same in the circuit? Justify your answer in each case.

(b) Why is a potentiometer preferred over a voltmeter? Give reason

**OR**

State the underlying principle of the meter bridge. Draw the circuit diagram and explain how the unknown resistance of a conductor can be determined by this method.

**Q.17. (a) Draw a graph showing the variation of current versus voltage in an electrolyte when an external resistance is also connected.**

**(b) (i) The graph between resistance (R) and temperature (T) for Hg is shown in figure**

**(a). Explain the behavior of Hg near 4 K.**

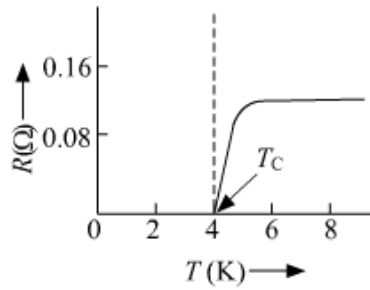

(ii) In which region of the graph shown in figure (b) is resistance negative and why?

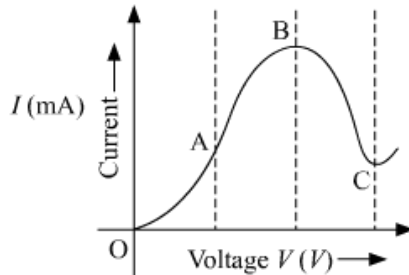

**Solution:**

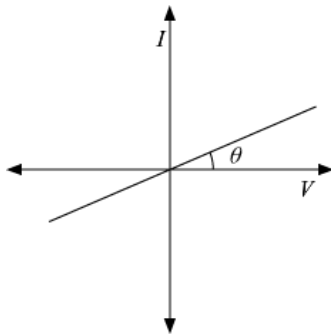

When an external resistance is also connected in an electrolyte, the voltage across the electrodes will reduce, so does the current in the circuit. If we plot a graph between Current in the circuit and the voltage, it still is a straight line but with the lesser slope. The slope of the graph will reduce because of the presence of external resistance in the circuit. Which simply means for the same value of current the circuit with external resistance will require more applied voltage than the circuit without external resistance.

(b) (i) Around 4K temperature, the resistance of mercury (Hg) becomes zero. Hence, it can be said that mercury behaves as a superconductor around 4K temperature.

(ii) In region BC, the slope of the I-V curve is negative, Hence, it can be said that in region BC the resistance is negative.

**Q.19.**



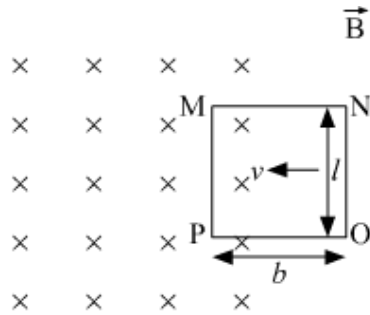

The figure shows a rectangular conducting frame MNOP of resistance R placed partly in a perpendicular magnetic field  $\vec{B}$  and moved with velocity  $\vec{v}$  as shown in the figure.

Obtain the expressions for the

- Force acting on the arm 'ON' and its direction, and
- power required to move the frame to get a steady emf induced between the arms MN and PO.

**Solution:**

As the conducting loop is moved with velocity  $\vec{v}$  inside the perpendicular magnetic field  $\vec{B}$  an emf is induced across the arm MP that is given by  $e = Blv$ . Due to this induced emf, the current starts flowing in the loop MNOP, that is given by  $i = \frac{e}{R} = \frac{Blv}{R}$ , the current will flow in direction ONMP.

- Force acting on the arm 'ON' can be calculated by the formula,  $\vec{F} = i \vec{l} \times \vec{B} = (ilB \sin \theta) \hat{n}$

As the magnetic field is perpendicular to the plane of the coil,  $\theta = 90^\circ$  and current is flowing along ON, hence the force on the current carrying arm ON is given by:

$$F = B \left( \frac{Blv}{R} \right) \times l = \frac{B^2 l^2 v}{R} \text{ and the force is in the direction opposite to the velocity } \vec{v}.$$

- The emf induced between the arms MN and PO can be steady if the frame is moved with a constant velocity. Power required to move the frame to get a steady emf can be calculated as:

$$P = Fv = \frac{B^2 l^2 v^2}{R}$$

**Q.20. Draw a ray diagram to show the image formation of a distant object by a refracting telescope. Write the expression for its angular magnification in terms of the focal lengths of the lenses used. State the important considerations required to achieve large resolution and their consequent limitations.**

OR

- Plot a graph for angle of deviation as a function of angle of incidence for a triangular prism.

(b) Derive the relation for the refractive index of the prism in terms of the angle of minimum deviation and angle of prism.

Q.20. Draw a ray diagram to show the image formation of a distant object by a refracting telescope. Write the expression for its angular magnification in terms of the focal lengths of the lenses used. State the important considerations required to achieve large resolution and their consequent limitations.

OR

(a) Plot a graph for angle of deviation as a function of angle of incidence for a triangular prism.

(b) Derive the relation for the refractive index of the prism in terms of the angle of minimum deviation and angle of prism.

Solution:

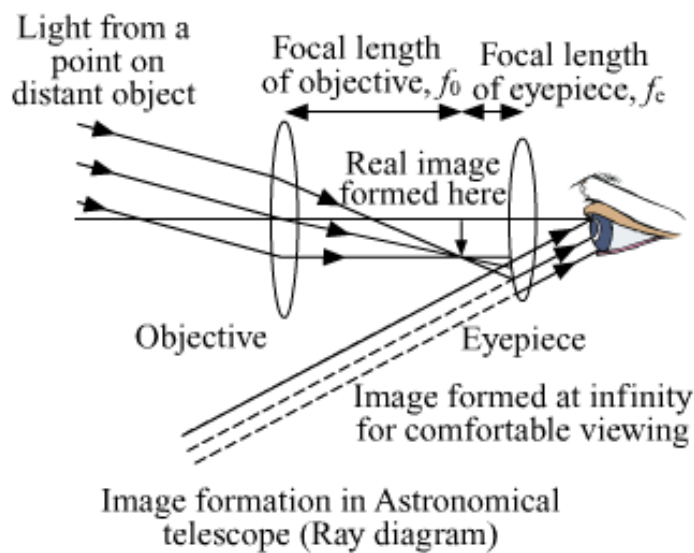

The expression for angular magnification of reflecting type telescope,

$$\text{Angular Magnification, } M = \frac{f_0}{f_e}$$

OR

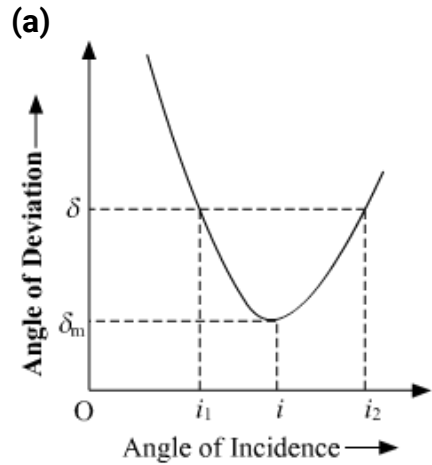

When the angle of incidence and angle of emergence are equal then the angle of deviation of the ray passing through the prism will be minimum.

(b) Let the angle of minimum deviation be  $\delta_m$ , for minimum deviation,  $i = i'$  and  $r = r'$ , we have,

$$\delta_m = i + i' - A = 2i - A$$

$$i = \frac{A + \delta_m}{2} \quad \dots (i)$$

Also,  $r + r' = A$

or,  $r = \frac{A}{2} \quad \dots (ii)$

The refractive index is

$$\mu = \frac{\sin i}{\sin r}$$

Using (i) and (ii), we get,

$$\mu = \frac{\sin\left(\frac{A + \delta_m}{2}\right)}{\sin \frac{A}{2}}$$

**Q.21. Draw the energy band diagram of (i) n-type, and (ii) p-type semiconductors at temperature  $T > 0$  K.**

**In the case of n-type Si-semiconductor, the donor energy level is slightly below the bottom of conduction band whereas in p-type semiconductor, the acceptor energy level is slightly above the top of the valence band. Explain, giving examples, what role do these energy levels play in conduction and valence bands.**

**Solution:** (i) Energy band diagram of n-type:

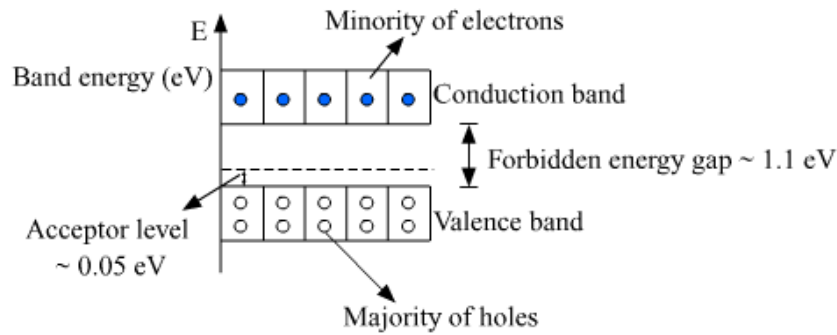

(ii) Energy band diagram of p-type:

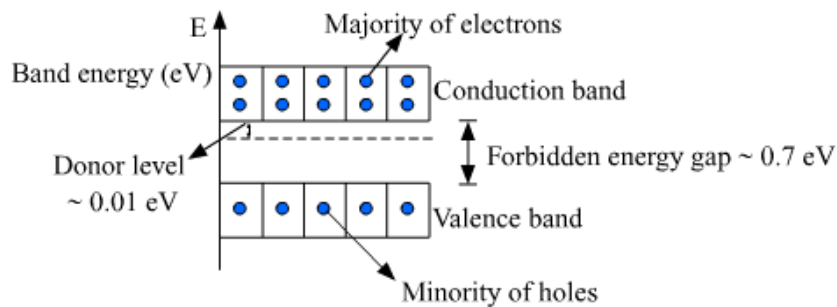

At a temperature of 0 K conduction band of the semiconductor is completely empty and it behaves as an insulator,

In case of n-type semiconductor and each donor, atom donates one electron as it completes its octet just by using its four electrons so it shows very less affinity for the fifth electron and fifth electron is almost free from the nuclear attraction and all these free electrons can easily go to the conduction band just by gaining little of energy. So these electrons form a new level of energy called donor impurity energy level that lies just below the conduction band. In case p-type semiconductor as each acceptor is responsible for one hole that is the absence of the electron in the covalent bond now the movement of the hole can, of course, enhance their. Conductivity but it requires breaking of the covalent bond so this fact makes them requires more energy than the fifth electron would need in case of the n-type semiconductor to participate in conduction. So, they form new energy bond that just lies above the valence band and it is called acceptor energy level.

**Q.22. (a) State briefly, with what purpose was Davisson and Germer's experiment performed and what inference was drawn from this.**

**(b) Obtain an expression for the ratio of the accelerating potentials required to accelerate a proton and an  $\alpha$ -particle to have the same de-Broglie wavelength associated with them.**

OR

(a) An electron and a proton are accelerated through the same potential. Which one of the two has

- (i) the greater value of de-Broglie wavelength associated with it, and
- (ii) lesser momentum ?

Justify your answer in each case.

(b) How is the momentum of a particle related with its de-Broglie wavelength? Show the variation on a graph.

**Solution:** (a) Purpose: The Davisson-Germer experiment demonstrated the wave nature of the electron, confirming the earlier hypothesis of de Broglie. Putting wave-particle duality on a firm experimental footing, it represented a major step forward in the development of quantum mechanics.

Inference: Davisson and Germer Experiment, for the first time, proved the wave nature of electrons and verified the de Broglie equation.

(b)  $E = hv$  as per Planck's quantum theory.

$E = mc^2$  as per Einstein's mass-energy relation.

So,  $hv = mc^2$

$$m = \frac{hv}{c^2}$$

And we know,  $P = mv$

$$\text{So, } P = \frac{hv}{C^2} \times C = \frac{hv}{c}$$

$$P = \frac{hv}{\left(\frac{c}{v}\right)} = \frac{hv}{\lambda}$$

$$\text{so, } \lambda = \frac{h}{p}$$

$$\text{Now } \varepsilon = \frac{1}{2}mv^2 = \frac{1}{2} \frac{m^2v^2}{m} = \frac{P^2}{2m}$$

$$P = \sqrt{2m\varepsilon} =$$

$$\text{Now } \lambda = \frac{h}{p}$$

$$\text{So, } \lambda = \frac{h}{\sqrt{2m\varepsilon}}$$

$$\text{Now } \varepsilon = qv$$

$$\lambda = \frac{h}{\sqrt{2mqv}}$$

$$\begin{aligned}\lambda_{\text{proton}} &= \lambda_p \\ m_{\text{proton}} &= m_p \\ q_{\text{proton}} &= q_p\end{aligned}$$

$$\begin{aligned}\lambda_{\text{alpha}} &= \lambda_\alpha \\ m_{\text{alpha}} &= m_\alpha \\ q_{\text{alpha}} &= q_\alpha\end{aligned}$$

$$\text{So, } \lambda_p = \frac{h}{\sqrt{2m_p q_p v_p}} \quad \& \quad \lambda_\alpha = \frac{h}{\sqrt{2m_\alpha q_\alpha v_\alpha}}$$

Now it's given that,

$$\lambda_p = \lambda_\alpha$$

$$\frac{k}{\sqrt{2m_p q_p v_p}} = \frac{k}{\sqrt{2m_\alpha q_\alpha v_\alpha}}$$

$$m_p q_p v_p = m_\alpha q_\alpha v_\alpha$$

$$\frac{v_p}{v_\alpha} = \frac{m_\alpha q_\alpha}{m_p q_p}$$

$$m_\alpha = u m_p \quad \& \quad q_\alpha = 2q_p$$

$$\text{so } \frac{v_p}{v_\alpha} = \frac{u m_p 2q_p}{m_p q_p} = 8$$

$$\Rightarrow \frac{v_p}{v_\alpha} = 8$$

**OR**

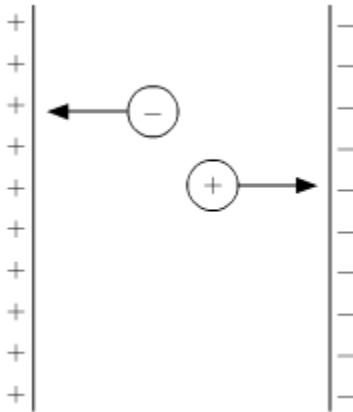

(i) According to De-Broglie equation:

$$\lambda = \frac{h}{mv} = \frac{h}{p}$$

$$KE = \frac{P^2}{2m}$$

$$\frac{1}{2}mv^2 = (qv)$$

$$\frac{P^2}{2m} = (qv)$$

$$P = \sqrt{2m(qv)}$$

$$\lambda = \frac{h}{\sqrt{2m(qv)}}$$

$$\lambda \propto \frac{1}{m}$$

$$\frac{\lambda_e}{\lambda_p} = \frac{m_p}{m_e}$$

as  $m_p > m_e$

then  $\lambda_e > \lambda_p$

(ii) Kinetic energy for the changes will be =  $(qv)$  and the same as well

$$(K.E.)_e = (K.E.)_p$$

$$\frac{P_e^2}{2m_e} = \frac{P_p^2}{2m_p}$$

$$\frac{P_e}{P_p} = \sqrt{\frac{m_e}{m_p}} < 1$$

$$\therefore P_e < P_p$$

Hence electron will have less momentum

(b) According to De-Broglie equation:-

$$\lambda = \frac{h}{mv}$$

$$\lambda = \frac{h}{p}$$

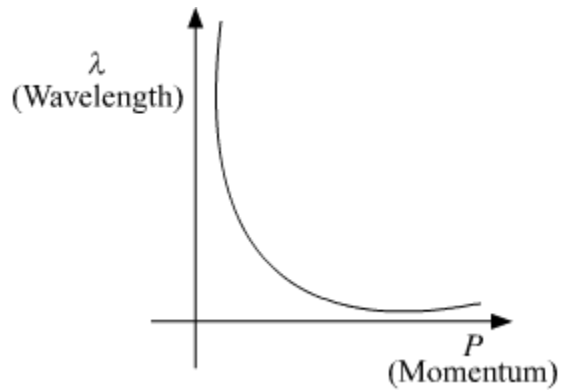

It'll be a Rectangular hyperbola

**Q.23. (a) What is amplitude modulation ? Draw a diagram showing an amplitude modulated wave obtained by modulation of a carrier sinusoidal wave on a modulating signal.**

**(b) Define the terms (i) modulation index, and (ii) side bands. Mention the significance of side bands.**

**Solution:** Amplitude Modulation:- (a) It is the process of varying the Amplitude of the carrier signal in accordance with the amplitude of the message signal, One important parameter associated with  $A_m$  is the modulation index. It is the Ratio of Amplitude of message signal to that of the carrier signal.

$$\mu = \frac{A_m}{A_c}$$

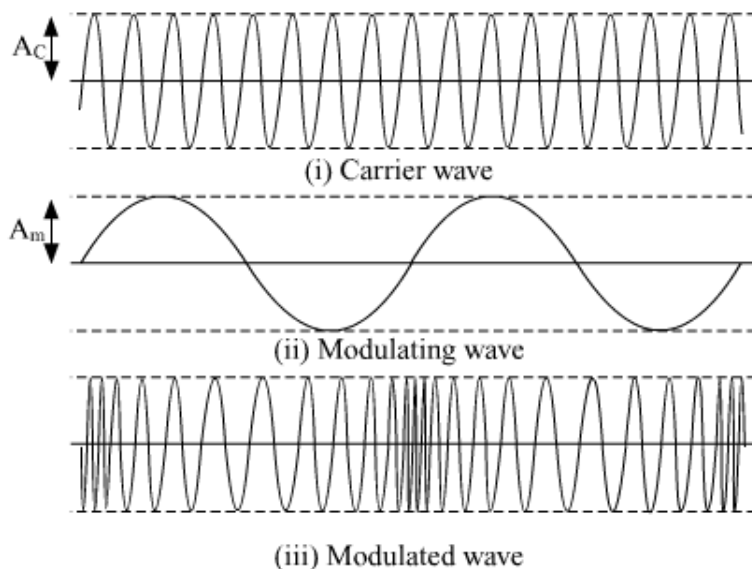

(b) It is Ratio of the Amplitude of the modulated wave to the Amplitude of the carrier wave.



$$\text{Modulation Index } (\mu) = \frac{A_m}{A_c}$$

usual modulation Index is kept  $\leq 1$  to avoid distortion.

(ii)

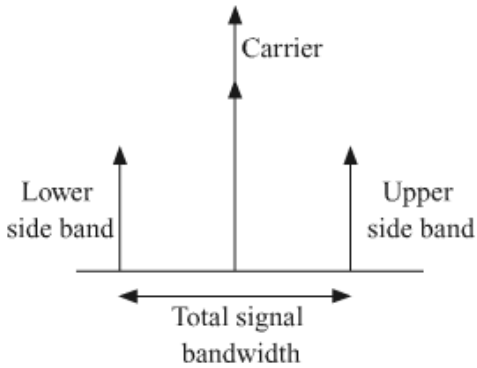

**Side Bands:-** Side bands are produced by modulations. The signal produced after modulation consist of frequencies slightly higher and slightly lower than the frequency of carrier wave ( $f_c + f_m$  and  $f_c - f_m$ ) called sidebands.

When a signal is modulated, two bands lower and upper sidebands will be formed in which the AM signal will be sent.

**Q.24. How is Zener diode fabricated ? Draw its I-V characteristic and use this to explain the working of a Zener diode as a voltage regulator.**

**Solution:**

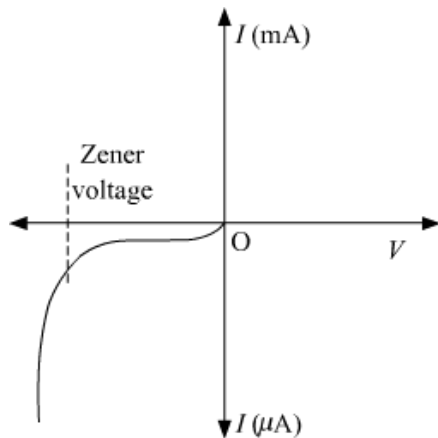

A Zener diode is fabricated by heavily doping both  $p$  and  $n$  sides of the junction. Because of the heavy doping, a very thin ( $< 10^{-6}m$ ) depletion region is formed between  $p$  and  $n$  sides. Hence the electric of the junction is extremely high ( $\sim 5 \times 10^6 v/m$ )

I-V characteristic:-

To get a constant *d.c.* the voltage from a *d.c.* the unregulated voltage output of a rectifier we use a Zener Diode the circuit diagram of a voltage. The unregulated *d.c* voltage is connected to the Zener diode through a series Resistance  $R_s$ . Such that the Zener diode is reverse biased. If the input voltage increases, the current through  $R_s$  and the Zener diode also increase. This increase the voltage drop across  $R_s$  without any change in voltage across the Zener diode. This is because the Zener Voltage remains constant in the breakdown region even though the current through it changes

**Q.25. (a) What do you understand by 'sharpness of resonance' for a series LCR resonant circuit ? How is it related with the quality factor 'Q' of the circuit ? Using the graphs given in the diagram, explain the factors which affect it. For which graph is the resistance (R) minimum ?**

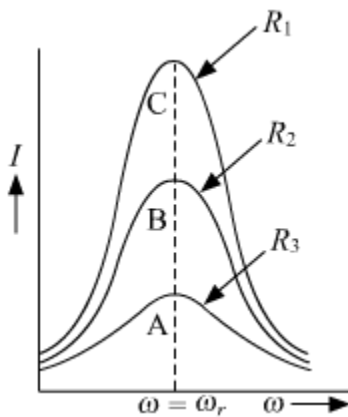

**(b) A  $2 \mu\text{F}$  capacitor,  $100 \Omega$  resistor, and  $8 \text{ H}$  inductor are connected in series with an ac source. Find the frequency of the ac source for which the current drawn in the circuit is maximum.**

**If the peak value of emf of the source is  $200 \text{ V}$ , calculate the (i) maximum current, and (ii) inductive and the capacitive reactance of the circuit at resonance.**

OR

**(a) Draw a schematic diagram of an ac generator. Explain its working and obtain the expression for the instantaneous value of the emf in terms of the magnetic field  $B$ , the number of turns  $N$  of the coil of area  $A$  rotating with angular frequency  $\omega$ . Show how an alternating emf is generated by a loop of wire rotating in a magnetic field.**

**(b) A circular coil of radius  $10 \text{ cm}$  and  $20$  turns is rotated about its vertical diameter with an angular speed of  $50 \text{ rad s}^{-1}$  in a uniform horizontal magnetic field of  $3.0 \times 10^{-2} \text{ T}$ .**

**(i) Calculate the maximum and average emf induced in the coil.**

(ii) If the coil forms a closed loop of resistance  $10 \Omega$ , calculate the maximum current in the coil and the average power loss due to Joule heating.

**Solution:** (a) Sharpness of resonance

When the resistance of an LCR circuit is very low, a large current flows and the angular frequency is close to the resonant frequency such as an LCR series circuit is said to be more selective or sharper.

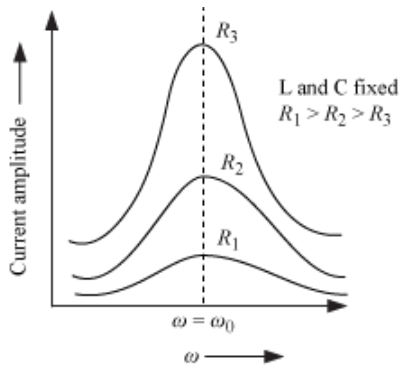

Suppose the value of  $\omega$  is such that the current in the circuit is  $1/\sqrt{2}$  times the current amplitude of resonance.

Two values are considered which are symmetrical about  $\omega_0$ .

$$\omega_1 = \omega_0 + \Delta\omega$$

$$\omega_2 = \omega_0 - \Delta\omega$$

i.e.,  $\omega_1 - \omega_2 = 2\Delta\omega$  is often called the bandwidth of the circuit

$\omega_0/2\Delta\omega$  - Measure of the sharpness of resonance

The mathematical expression for the sharpness of resonance

$$\frac{E}{\sqrt{R^2 + \left(\omega_1 L - \frac{1}{\omega_1 C}\right)^2}} = \frac{1}{\sqrt{2}} \times I(at\omega_0)$$

$$\therefore \frac{E}{\sqrt{R^2 + \left(\omega_1 L - \frac{1}{\omega_1 C}\right)^2}} = \frac{1}{\sqrt{2}} \times \frac{E}{R}$$

$$\left[ \because I(at\omega_0) = \frac{E}{R} \right]$$

$$\Rightarrow \sqrt{R^2 + \left(\omega_1 L - \frac{1}{\omega_1 C}\right)^2} = \sqrt{2}R$$

$$\Rightarrow R^2 + \left(\omega_1 L - \frac{1}{\omega_1 C}\right)^2 = 2R^2$$

$$\Rightarrow \left( \omega_1 L - \frac{1}{\omega_1 C} \right)^2 = R^2$$

$$\Rightarrow \left( \omega_1 L - \frac{1}{\omega_1 C} \right) = R$$

$$\Rightarrow (\omega_0 - \Delta\omega)L - \frac{1}{(\omega_0 - \Delta\omega)C} = R$$

$$\Rightarrow \omega_0 L \left( 1 + \frac{\Delta\omega}{\omega_0} \right) - \frac{1}{\omega_0 C \left( 1 + \frac{\Delta\omega}{\omega_0} \right)} = R$$

$$\Rightarrow \omega_0 L \left( 1 + \frac{\Delta\omega}{\omega_0} \right) - \frac{\omega_0 L}{\left( 1 + \frac{\Delta\omega}{\omega_0} \right)} = R$$

$$\left( \because \omega_0 C = \frac{1}{\omega_0 L} \right)$$

$$\Rightarrow \omega_0 L \left( 1 + \frac{\Delta\omega}{\omega_0} \right) - \omega_0 L \left( 1 + \frac{\Delta\omega}{\omega_0} \right)^{-1} = R$$

$$\Rightarrow \omega_0 L \left( 1 + \frac{\Delta\omega}{\omega_0} \right) - \omega_0 L \left( 1 - \frac{\Delta\omega}{\omega_0} \right) = R$$

$$\Rightarrow \omega_0 L \times \frac{2\Delta\omega}{\omega_0} = R$$

$$\Rightarrow \Delta\omega = \frac{R}{2L}$$

$\therefore$  Sharpness of resonance

$$\frac{\omega_0}{2\Delta\omega} = \frac{\omega_0 L}{R}$$

The ratio  $\frac{\omega_0 L}{R}$  is also called quality factor Q of the circuit.

$$\therefore Q = \frac{\omega_0 L}{R} = \frac{1}{\sqrt{LC}} \frac{L}{R}$$

$$= \frac{1}{R} \sqrt{\frac{L}{C}}$$

Sharpness is inversely proportional to Resistance hence  $R_1 < R_2 < R_3$

Sharpness is inversely proportional to Resistance hence  $R_1 < R_2 < R_3$

(b)  $C = 2 \mu\text{F}$

$R = 100 \Omega$

$L = 8 \text{ H}$

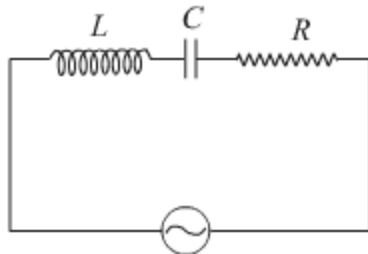

We get maximum current when the LCR Series Circuit is at resonance.

*i. e.*  $X_C = X_L$

$$\frac{1}{\omega C} = \omega L$$

*i. e.*  $\omega^2 = \frac{1}{LC}$

$$\omega = \frac{1}{\sqrt{LC}}$$

$$\text{So, } \omega = \frac{1}{\sqrt{8 \times 2 \times 10^{-6}}} = \sqrt{\frac{10^6}{16}} = \frac{10^3}{4}$$

$$\omega = 250$$

$$\text{Frequency } \frac{\omega}{2\pi} = \frac{250}{2\pi} \simeq u_o \text{ Hz}$$

$$\text{Now, Peak Current} = \frac{\text{Peak Emp}}{\text{Resistance}} \left( \text{at Resonance} \right)$$

$$\text{Peak Current} = \frac{200}{100} = 2 \text{ A}$$

$$\text{Inductive reactance} = \omega L = 250 \times 8 = 2000 \Omega$$

$$\text{Capacitive reactance} = \frac{1}{\omega C} = \frac{10^6}{250 \times 2} = 2000 \Omega \text{ at resonance}$$

(a) Principle – Based on the phenomenon of electromagnetic induction

**Construction:**

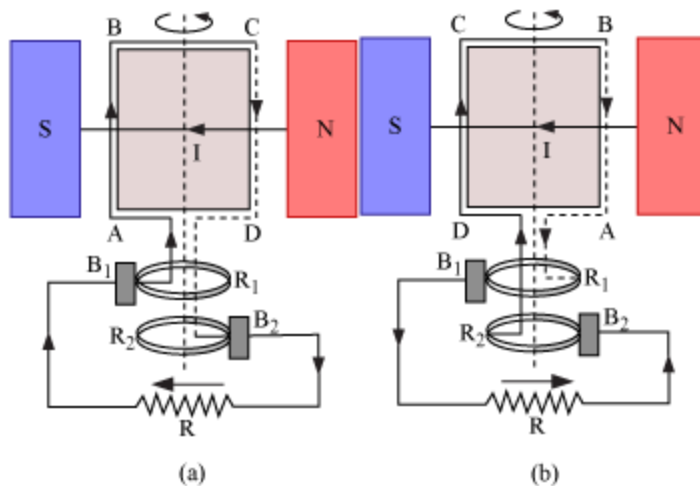

**Main parts of an ac generator:**

Armature – Rectangular coil ABCD

Filed Magnets – Two pole pieces of a strong electromagnet

Slip Rings – The ends of coil ABCD are connected to two hollow metallic rings  $R_1$  and  $R_2$ .

Brushes –  $B_1$  and  $B_2$  are two flexible metal plates or carbon rods. They are fixed and are kept in tight contact with  $R_1$  and  $R_2$  respectively.

**Theory and Working** – As the armature coil is rotated in the magnetic field, angle  $\theta$  between the field and normal to the coil changes continuously. Therefore, magnetic flux linked with the coil changes. An emf is induced in the coil. According to Fleming's right-hand rule, current induced in AB is from A to B and it is from C to D in CD. In the external circuit, current flows from  $B_2$  to  $B_1$ .

To calculate the magnitude of emf induced:  
Suppose,

A → Area of each turn of the coil

N → Number of turns in the coil

$\vec{B}$  → The strength of the magnetic field

$\theta$  → Angle which normal to the coil makes with  $\vec{B}$  at any instant t

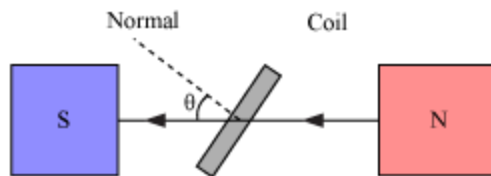

∴ Magnetic flux linked with the coil in this position:

$$\phi = N(\vec{B} \cdot \vec{A})$$

$$= NBA \cos\theta = NBA \cos\omega t \dots(i)$$

Where ' $\omega$ ' is the angular velocity of the coil

As the coil rotates, angle  $\theta$  changes. Therefore, magnetic flux  $\Phi$  linked with the coil changes and hence, an emf is induced in the coil. At this instant t, if e is the emf induced in the coil, then

$$e = -\frac{d\phi}{dt} = -\frac{d}{dt}(NAB \cos\omega t)$$

$$= -NAB \frac{d}{dt}(\cos\omega t)$$

$$= -NAB(-\sin\omega t)\omega$$

$$\therefore e = NAB \omega \sin\omega t$$

(b)

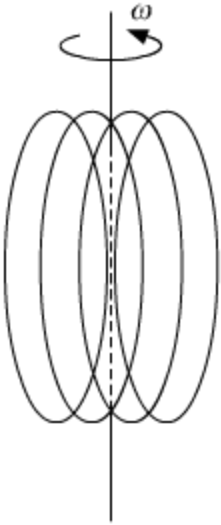

$$\rightarrow B = 3.0 \times 10^{-2} \text{ T}$$

Radius = 10cm

N = 20 turns

$\omega = 50 \text{ rad/sec.}$

Expression for emf produced =  $NAB \omega \sin(\omega t)$

(i) Max emf =  $NAB \omega = 20 \times \pi (0.1)^2 \times 3.0 \times 10^2 \times 50 = 0.942\text{V}$

Average emf = 0

(i) Max emf =  $NAB \omega = 20 \times \pi (0.1)^2 \times 3.0 \times 10^2 \times 50 = 0.942\text{V}$

Average emf = 0

(ii) Max current =  $\frac{\text{Max voltage}}{\text{Resistance}} = \frac{0.942}{10} = 0.0942 \text{ A}$

$$\text{power loss} = VI = \left( \frac{NAB\omega \sin \omega t}{R} \right)^2 = \left( \frac{V^2}{R} \right)$$

$$= \frac{(NAB\omega)^2}{R} \sin^2(\omega t)$$

average of  $\sin^2 \omega t = 1/2$

So, average power loss =  $\frac{(NAB\omega)^2}{R} \text{Sin}^2(\omega T)$

average of  $\sin^2 \omega t = 1/2$



$$\begin{aligned} \text{So average power loss} &= \frac{(NAB\omega)^2}{2R} \\ &= \frac{(0.942)^2}{2 \times 10} \\ &= 0.04436 \text{ J/s} \end{aligned}$$

**Q.26. (a)** Using the ray diagram for a system of two lenses of focal lengths  $f_1$  and  $f_2$  in contact with each other, show that the two lens system can be regarded as equivalent to a single lens of focal length  $f$ , where

$$\frac{1}{f} = \frac{1}{f_1} + \frac{1}{f_2}.$$

Also, write the relation for the equivalent power of the lens combination.

**(b)** Determine the position of the image formed by the lens combination given in the figure.

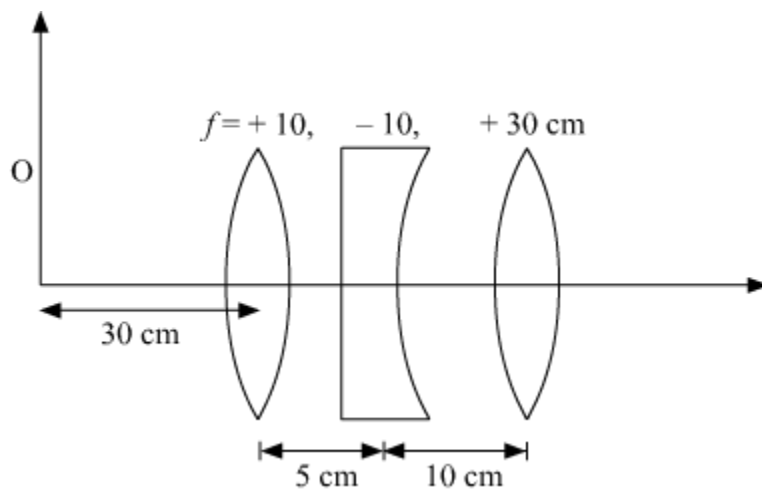

OR

**(a)** Explain, using a suitable diagram, how unpolarized light gets linearly polarized by scattering.

**(b)** Describe briefly the variation of the intensity of transmitted light when a polaroid sheet kept between two crossed polaroids is rotated. Draw the graph depicting the variation of intensity with the angle of rotation. How many maxima and minima would be observed when  $\theta$  varies from  $0$  to  $\pi$ ?

**Solution:** (a) Consider two thin convex lens  $L_1$  and  $L_2$  of focal length  $f_1$  and  $f_2$  held coaxially in contact with each other. Let  $P$  be the point where the optical centers of the lenses coincide (lenses being thin).

Let the object be placed at a point  $O$  beyond the focus of the lens  $L_1$  such that  $OP = u$  (Object distance). Lens  $L_1$  alone forms the image  $I_1$  where  $PI_1 = v_1$  (Image

distance). The image  $I_1$  would serve as a virtual object for lens  $L_2$  which forms a final image  $I$  at a distance  $PI = v$ . The ray diagram showing the image formation by the combination of these two thin convex lenses will be as shown below:

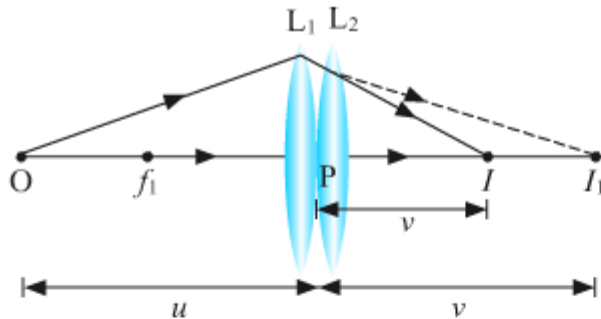

From the lens formula, for the image  $I_1$  formed by the lens  $L_1$ , we have,

$$\frac{1}{v_1} - \frac{1}{u} = \frac{1}{f_1} \quad \dots\dots (1)$$

For the image formed by the lens,  $L_2$ :

$$\frac{1}{v} - \frac{1}{v_1} = \frac{1}{f_2} \quad \dots\dots (2)$$

Adding (1) and (2) we get,

$$\frac{1}{v_1} - \frac{1}{u} + \frac{1}{v} - \frac{1}{v_1} = \frac{1}{f_1} + \frac{1}{f_2}$$

$$-\frac{1}{u} + \frac{1}{v} = \frac{1}{f_1} + \frac{1}{f_2}$$

$$\frac{1}{v} - \frac{1}{u} = \frac{1}{f_1} + \frac{1}{f_2}$$

$$\frac{1}{v} - \frac{1}{u} = \frac{1}{f} \quad \left[ \text{Where, } \frac{1}{f} = \frac{1}{f_1} + \frac{1}{f_2} \right]$$

The above relation shows that the two lenses can be regarded as the single lens of focal length  $f$ , forms an image  $I$  at a distance  $v$  with an object distance being  $u$ .

The relation for the equivalent power of the lens combination is given by

$$P = P_1 + P_2$$

In general,

$$P = P_1 + P_2 + P_3 + \dots$$

(b) For the first lens,

Let  $f_1 = +10$  cm

$u = -30$  cm

As we know,

$$\frac{1}{v_1} - \frac{1}{u_1} = \frac{1}{f_1}$$
$$\frac{1}{v_1} = \frac{1}{10} - \frac{1}{30} = \frac{1}{15}, v_1 = 15 \text{ cm}$$

Image formed by the first lens will act an object for the second lens (concave) at a distance =  $(15 - 5) = 10$  cm to the right of the second lens, and the object is virtual. Therefore, for the second lens,

$u_2 = 10$  cm

$f_2 = -10$  cm

As,

$$\frac{1}{f_2} = \frac{1}{v_2} - \frac{1}{u_2}$$
$$\frac{1}{-10} = \frac{1}{v_2} - \frac{1}{10}$$
$$\frac{1}{v_2} = 0$$
$$\Rightarrow v_2 = \infty$$

The virtual image is formed at infinity to the right of the second lens. This acts as an object for the third lens.

Therefore,

$u_3 = \infty$

$f_3 = +30$  cm

And,

$$\frac{1}{v_3} - \frac{1}{u_3} = \frac{1}{f_3}$$
$$\frac{1}{v_3} - \frac{1}{\infty} = \frac{1}{30}$$
$$v_3 = 30 \text{ cm}$$

Hence, the final image will be formed at 30 cm on the right side of the third lens.

OR

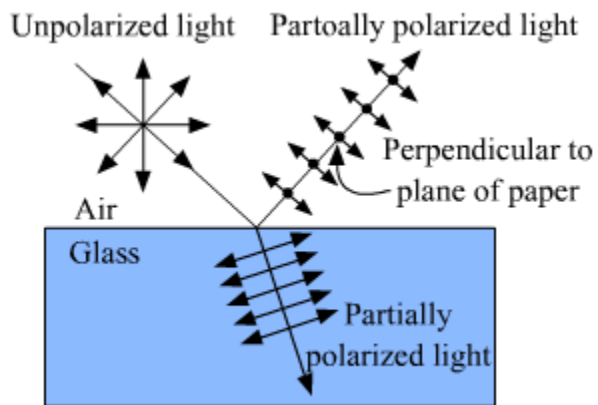

When unpolarized light falls on a refracting medium some part of the light is refracted and some part is reflected. These reflected and refracted light is partially polarized and separated by an angle of  $\pi/2$ . The reflected polarized light is called polarisation by scattering.

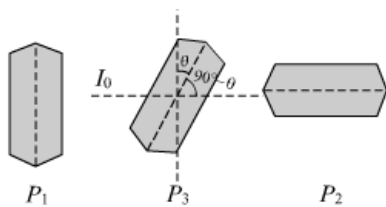

Let the rotating polaroid sheet makes an angle  $\theta$  with the first polaroid. So, the angle with the other polaroid will be  $(90^\circ - \theta)$ . Let the intensity from the first polaroid be  $I_0$ , then by malus law the intensity by the polaroid  $P_2$  is given by

$$I' = I_0 \cos^2 \theta$$

And by the third polaroid  $P_3$  is given by

$$I'' = (I_0 \cos^2 \theta) \cos^2 (90^\circ - \theta)$$

$$I'' = \frac{I_0}{4} \sin^2 \theta$$

Transmitted intensity will be maximum when  $\sin^2 2\theta = 1$

$$\sin^2 2\theta = \sin^2 \frac{\pi}{2}$$

$$2\theta = \frac{\pi}{2}$$

$$\theta = \frac{\pi}{4}$$

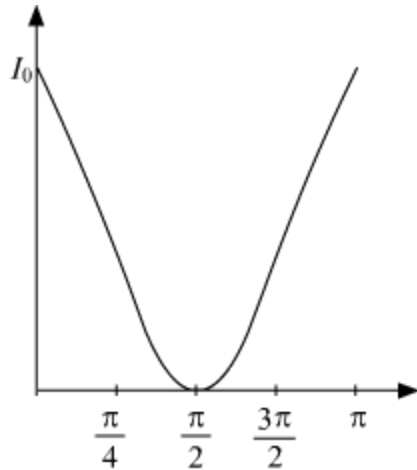

From the graph, we can see that there will be two maxima and one minimum would be observed when  $\theta$  varies from 0 to  $\pi$ .

**Q.27. (a) When a parallel plate capacitor is connected across a dc battery, explain briefly how the capacitor gets charged.**

**(b) A parallel plate capacitor of capacitance 'C' is charged to 'V' volt by a battery. After some time the battery is disconnected and the distance between the plates is doubled. Now a slab of dielectric constant  $1 < k < 2$  is introduced to fill the space between the plates. How will the following be affected?**

**(i) The electric field between the plates of the capacitor.**

**(ii) The energy stored in the capacitor**

**Justify your answer in each case.**

**(c) The electric potential as a function of distance 'x' is shown in the figure. Draw a graph of the electric field E as a function of x.**

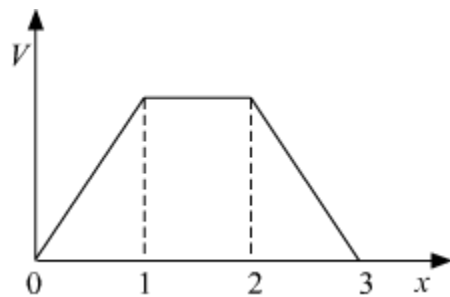

**(a) Derive an expression for the potential energy of an electric dipole in a uniform electric field. Explain conditions for stable and unstable equilibrium.**

**(b) Is the electrostatic potential necessarily zero at a point where the electric field is zero? Give an example to support your answer.**

**Solution:**

(a)

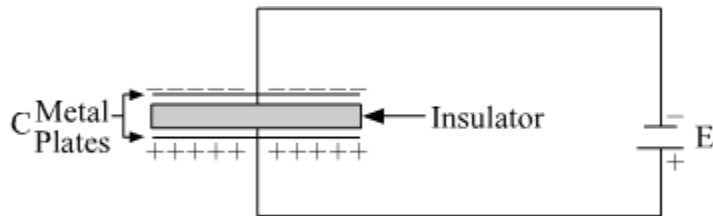

Consider a parallel plate capacitor connected across a d.c. the battery as shown in the figure. When the electric current will start flowing through the circuit. The insulating gap does not allow the charges to move further when the charges reach the plate of the capacitor. Hence, negative and positive charges get deposited on either side of the plates of the capacitor, respectively. As the voltage begins to develop, the electric charge begins to resist the deposition of further charge. Thus, the current flowing through the circuit gradually becomes less and then zero till the voltage of the capacitor is exactly equal but opposite to the voltage of the battery. This is how the capacitor gets charged when it is connected across a d.c. battery.

(b) Let the area of the plates be  $A$ , and the distance between them be  $d$

Then capacitance before the insertion of the dielectric slab will be,

$$C = \frac{\epsilon_0 A}{d}$$

Capacitance after the insertion of the dielectric slab and doubling distance between the plates will be

$$C' = \frac{\epsilon_0 k A}{2d}$$

Let the battery charge the plate with charge  $Q$ . The electric field between the plates will be given by:

Before the insertion of the dielectric slab,

$$E = \frac{V}{d}$$

After the insertion of the dielectric slab and doubling the distance between the plate,

$$E' = \frac{V}{2dk} = \frac{1}{2} \left( \frac{E}{k} \right)$$

After increasing the distance twice, the electric inside the capacitor reduced to half.

Energy stored in the capacitor is given by:

Initial energy before insertion of the dielectric.

$$E = \frac{1}{2} CV^2$$

$$V = \frac{Q}{C}$$

$$\Rightarrow E = \frac{1}{2} \frac{Q^2}{C}$$

As we know,

$$C = \frac{\epsilon_0 A}{d}$$

$$E = \frac{1}{2} \frac{Q^2 d}{\epsilon_0 A}$$

Final energy after the insertion of the dielectric and doubling the distance between the plate is given by,

$$E' = \frac{1}{2} \frac{(2d)Q^2}{\epsilon_0 kA}$$

$$E' = 2 \left( \frac{E}{k} \right)$$

The energy stored in the capacitor will get increased.

(c) As we know,

$$E = -\frac{dV}{dx}$$

So, the slope of potential v/s  $x$ , will give the value of  $E$ .

Now, in the figure, from  $x = 0$  to  $1$ , the slope is constant, from  $x = 1$  to  $2$ , the slope is zero and from  $x = 2$  to  $3$ , the slope is again constant.

Therefore, the graph of  $E$  v/s  $x$  will be:

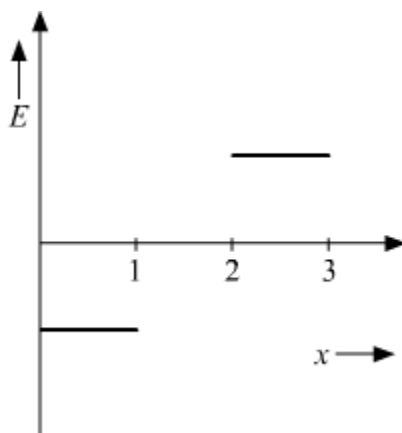

OR

Potential Energy of an Electric Dipole, When Placed in a Uniform Electric Field

Suppose an electric dipole of dipole moment  $p$  is placed along a direction, making an angle  $\theta$  with the direction of an external uniform electric field  $E$ . Then, the torque acting on the dipole is given by

$$\tau = PE \sin \theta$$

$$dW = \rho d\theta = PE \sin \theta d\theta$$

If the dipole is oriented, making an angle  $\theta_1$  to  $\theta_2$  with the electric field, then the total work done is given by

$$dW = \int_{\theta_1}^{\theta_2} PE \sin \theta d\theta = PE [-\cos \theta]_{\theta_1}^{\theta_2}$$

$$W = PE (\cos \theta_1 - \cos \theta_2)$$

This work done is stored in the dipole in the form of its potential energy.

$$U = pE(\cos 90^\circ - \cos \theta)$$

$$U = -pE \cos \theta$$

$$U = -\vec{P} \cdot \vec{E}$$

The below diagram shows the stable equilibrium of the electric dipole in an external electric field.

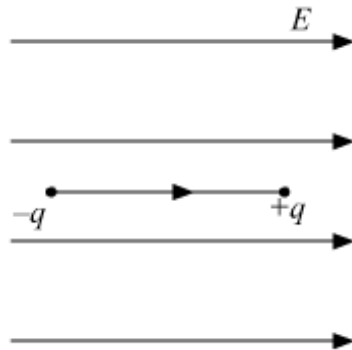

This is stable equilibrium because the potential energy of the dipole here is minimum.  
As,



$$U_e = -\mathbf{P} \cdot \mathbf{E} = -PE \cos 0 = -PE$$

The below diagram shows the electric dipole in an unstable equilibrium in an external electric field.

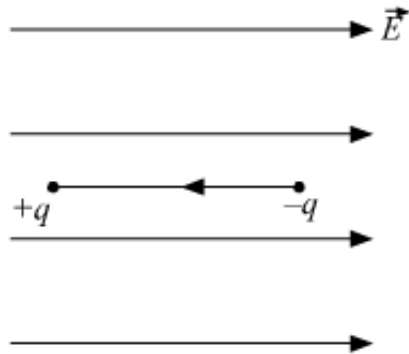

Here, the dipole is in unstable equilibrium. Because its potential energy is having its maximum value.

$$U_e = -\mathbf{P} \cdot \mathbf{E} = -PE \cos 180^\circ = +PE$$

(b) No, electric field can be zero even when potential has a value but is constant

Since,  $\mathbf{E} = -\frac{dV}{dr}$

Consider the following example to show that it is possible to have a zero electric field, and a positive electric potential at a given point. If you have two positive point charges that are separated from each other, there is a point between them where the electric field is zero. The electric field of each is a vector quantity, and the two vectors cancel each other. The electric potential is a scalar quantity, and at the same point, it is the sum of the two values.