

Series : ONS/2

कोड नं. **55/2/1/F**
Code No.

रोल नं.

--	--	--	--	--	--	--

Roll No.

परीक्षार्थी कोड को उत्तर-पुस्तिका के मुख-पृष्ठ पर अवश्य लिखें ।

Candidates must write the Code on the title page of the answer-book.

- कृपया जाँच कर लें कि इस प्रश्न-पत्र में मुद्रित पृष्ठ **16** हैं ।
- प्रश्न-पत्र में दाहिने हाथ की ओर दिए गए कोड नम्बर को छात्र उत्तर-पुस्तिका के मुख-पृष्ठ पर लिखें ।
- कृपया जाँच कर लें कि इस प्रश्न-पत्र में **26** प्रश्न हैं ।
- कृपया प्रश्न का उत्तर लिखना शुरू करने से पहले, प्रश्न का क्रमांक अवश्य लिखें ।
- इस प्रश्न-पत्र को पढ़ने के लिए 15 मिनट का समय दिया गया है । प्रश्न-पत्र का वितरण पूर्वाह्न में 10.15 बजे किया जायेगा । 10.15 बजे से 10.30 बजे तक छात्र केवल प्रश्न-पत्र को पढ़ेंगे और इस अवधि के दौरान वे उत्तर-पुस्तिका पर कोई उत्तर नहीं लिखेंगे ।
- Please check that this question paper contains **16** printed pages.
- Code number given on the right hand side of the question paper should be written on the title page of the answer-book by the candidate.
- Please check that this question paper contains **26** questions.
- **Please write down the Serial Number of the question before attempting it.**
- 15 minute time has been allotted to read this question paper. The question paper will be distributed at 10.15 a.m. From 10.15 a.m. to 10.30 a.m., the students will read the question paper only and will not write any answer on the answer-book during this period.

भौतिक विज्ञान (सैद्धान्तिक)

PHYSICS (Theory)

निर्धारित समय : 3 घंटे

अधिकतम अंक : 70

Time allowed : 3 hours

Maximum Marks : 70

सामान्य निर्देश :

- इस प्रश्न-पत्र में कुल **26** प्रश्न हैं । **सभी** प्रश्न अनिवार्य हैं ।
- इस प्रश्न-पत्र के **5** भाग हैं : **खण्ड-क, खण्ड-ख, खण्ड-ग, खण्ड-घ और खण्ड-ङ** ।
- खण्ड-क** में **5** प्रश्न प्रत्येक **1** अंक का, **खण्ड-ख** में **5** प्रश्न प्रत्येक **2** अंक के, **खण्ड-ग** में **12** प्रश्न प्रत्येक **3** अंक के, **खण्ड-घ** में **4** अंक का एक मूल्याधारित प्रश्न और **खण्ड-ङ** में **3** प्रश्न प्रत्येक **5** अंक के दिए गए हैं ।
- समग्र पर कोई विकल्प नहीं है । फिर भी **2** अंक के **1** प्रश्न, **3** अंक के **1** प्रश्न और **5** अंकों के **3** प्रश्नों में भीतरी विकल्प दिए गए हैं । ऐसे प्रश्नों में आपको विकल्पों में से एक को हल करना है ।

(v) जहाँ आवश्यक हो, वहाँ आप भौतिक अचरों के निम्नलिखित मूल्यों का उपयोग कर सकते हैं :

$$c = 3 \times 10^8 \text{ m/s}$$

$$h = 6.63 \times 10^{-34} \text{ Js}$$

$$e = 1.6 \times 10^{-19} \text{ C}$$

$$\mu_0 = 4 \times 10^{-7} \text{ T m A}^{-1}$$

$$\epsilon_0 = 8.854 \times 10^{-12} \text{ C}^2 \text{ N}^{-1} \text{ m}^{-2}$$

$$\frac{1}{4\pi\epsilon_0} = 9 \times 10^9 \text{ N m}^2 \text{ C}^{-2}$$

$$m_e = 9.1 \times 10^{-31} \text{ kg}$$

$$\text{न्यूट्रॉन का द्रव्यमान} = 1.675 \times 10^{-27} \text{ kg}$$

$$\text{प्रोटोन का द्रव्यमान} = 1.673 \times 10^{-27} \text{ kg}$$

$$\text{ऐवोगेड्रो संख्या} = 6.023 \times 10^{23} \text{ प्रति ग्राम मोल}$$

$$\text{बॉल्ट्ज़मान नियतांक} = 1.38 \times 10^{-23} \text{ JK}^{-1}$$

General Instructions :

- (i) All questions are compulsory. There are 26 questions in all.
- (ii) This question paper has **five** sections : Section A, Section B, Section C, Section D and Section E.
- (iii) Section A contains **five** questions of **one** mark each, Section B contains **five** questions of **two** marks each, Section C contains **twelve** questions of **three** marks each, Section D contains **one** value based question of **four** marks and Section E contains **three** questions of **five** marks each.
- (iv) There is no overall choice. However, an internal choice has been provided in **one** question of **two** marks, **one** question of **three** marks and all the **three** questions of **five** marks weightage. You have to attempt only **one** of the choices in such questions.
- (v) You may use the following values of physical constants wherever necessary :

$$c = 3 \times 10^8 \text{ m/s}$$

$$h = 6.63 \times 10^{-34} \text{ Js}$$

$$e = 1.6 \times 10^{-19} \text{ C}$$

$$\mu_0 = 4 \times 10^{-7} \text{ T m A}^{-1}$$

$$\epsilon_0 = 8.854 \times 10^{-12} \text{ C}^2 \text{ N}^{-1} \text{ m}^{-2}$$

$$\frac{1}{4\pi\epsilon_0} = 9 \times 10^9 \text{ N m}^2 \text{ C}^{-2}$$

$$\text{Mass of electron} = 9.1 \times 10^{-31} \text{ kg}$$

$$\text{Mass of neutron} = 1.675 \times 10^{-27} \text{ kg}$$

$$\text{Mass of proton} = 1.673 \times 10^{-27} \text{ kg}$$

$$\text{Avogadro's number} = 6.023 \times 10^{23} \text{ per gram mole}$$

$$\text{Boltzmann constant} = 1.38 \times 10^{-23} \text{ JK}^{-1}$$

खण्ड – क

Section – A

1. आरेख में दर्शाए अनुसार बिन्दु O पर कोई बिन्दुविकृत आवेश Q स्थित है । विभवान्तर $V_A - V_B$ धनात्मक है । आवेश Q धनात्मक है अथवा ऋणात्मक ? 1



A point charge Q is placed at point O as shown in the figure. The potential difference $V_A - V_B$ positive. Is the charge Q negative or positive ?

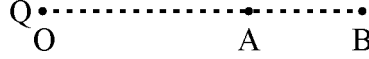

2. किसी प्रति-चुम्बकीय पदार्थ की उपस्थिति में चुम्बकीय क्षेत्र रेखाओं का व्यवहार चित्रित कीजिए । 1
Depict the behaviour of magnetic field lines in the presence of a diamagnetic material.
3. किसी संधारित्र के लिए आवेशन धारा 0.25 A है । इसकी पट्टिकाओं के आर-पार विस्थापन धारा क्या है ? 1
The charging current for a capacitor is 0.25 A. What is the displacement current across its plates ?
4. भंवर धाराओं के उपयोग का एक उदाहरण दीजिए । 1
Give one example of use of eddy currents.
5. विद्युत फ्लक्स की परिभाषा और इसका S.I. मात्रक लिखिए । 1
Define Electric Flux. Write its SI unit.

खण्ड – ख

Section – B

6. (i) बोर के हाइड्रोजन परमाणु के उस अभिगृहीत का उल्लेख कीजिए जो संक्रमण में उत्सर्जित फोटॉन की आवृत्ति के लिए संबंध प्रदान करता है । 2
- (ii) किसी परमाणु में कोई इलेक्ट्रॉन चौथी कक्षा से पहली कक्षा में कूदान करता है । इस परमाणु द्वारा कितनी अधिकतम संख्या की स्पेक्ट्रमी रेखाएँ उत्सर्जित की जा सकती हैं ? ये रेखाएँ किस श्रेणी के तदनरूपी हैं ?

अथवा

कक्षीय कोणीय संवेग की बोर की क्वान्टमीकरण शर्त के पदों में बोर-कक्षा की n वीं त्रिज्या के लिए संबंध लिखने के लिए दे-ब्रॉग्ली परिकल्पना का उपयोग कीजिए ।

- (i) State Bohr postulate of hydrogen atom that gives the relationship for the frequency of emitted photon in a transition.
- (ii) An electron jumps from fourth to first orbit in an atom. How many maximum number of spectral lines can be emitted by the atom ? To which series these lines correspond ?

OR

Use de-Broglie's hypothesis to write the relation for the n^{th} radius of Bohr orbit in terms of Bohr's quantization condition of orbital angular momentum.

7. संचार व्यवस्था में उपयोग होने वाली कोई युक्ति 'X' ऊर्जा को एक रूप से दूसरे रूप में परिवर्तित कर सकती है। युक्ति 'X' का नाम लिखिए। किसी संचार व्यवस्था में पुनरावर्तक के कार्य की व्याख्या कीजिए। 2

A device X used in communication system can convert one form of energy into another. Name the device X. Explain the function of a repeater in a communication system.

8. किसी फोटॉन की तरंगदैर्घ्य λ तथा किसी इलेक्ट्रॉन की दे-ब्रॉग्ली तरंगदैर्घ्य समान हैं। यह दर्शाइए कि फोटॉन की ऊर्जा इलेक्ट्रॉन की गतिज ऊर्जा की $(2\lambda mc/h)$ गुनी है। यहाँ m , c और h के अर्थ सामान्य हैं। 2

The wavelength λ of a photon and the de-Broglie wavelength of an electron have the same value. Show that energy of a photon is $(2\lambda mc/h)$ times the kinetic energy of electron; where m , c and h have their usual meaning.

9. ध्रुवित प्रकाश और अध्रुवित प्रकाश में विभेदन कीजिए। क्या किसी पोलैरोइड द्वारा उत्सर्जित ध्रुवित प्रकाश की तीव्रता उसके अभिविन्यास पर निर्भर करती है ? संक्षिप्त में व्याख्या कीजिए।

ध्रुवित प्रकाश के किसी पुंज के कम्पन पोलैरोइड शीट के अक्ष के साथ 60° का कोण बनाते हैं। प्रकाश का कितना प्रतिशत इस शीट से पारगमित होगा ? 2

Distinguish between polarized and unpolarized light. Does the intensity of polarized light emitted by a polaroid depend on its orientation ? Explain briefly.

The vibrations in a beam of polarized light make an angle of 60° with the axis of the polaroid sheet. What percentage of light is transmitted through the sheet ?

10. लम्बाई l तथा वर्गाकार अनुप्रस्थकाट क्षेत्रफल A की किसी धातु की छड़ के सिरों पर V वोल्ट का विभवान्तर लगाने पर उससे धारा I प्रवाहित होती है (चित्र I) । अब इस छड़ को इसकी लम्बाई के समान्तर दो सर्वसम भागों में काटकर चित्र II में दर्शाए अनुसार जोड़ दिया जाता है । इस छड़ की लम्बाई $2l$ के सिरों पर कितना विभवान्तर बनाए रखा जाए कि इस छड़ से अब भी वही धारा I प्रवाहित हो ?

2

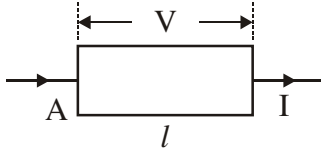

चित्र - I

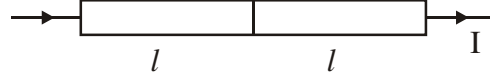

चित्र - II

A metal rod of square cross-sectional area A having length l has current I flowing through it when a potential difference of V volt is applied across its ends (figure I). Now the rod is cut parallel to its length into two identical pieces and joined as shown in figure II. What potential difference must be maintained across the length $2l$ so that the current in the rod is still I ?

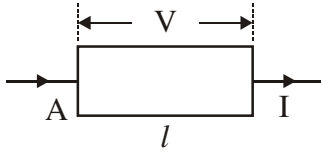

Figure - I

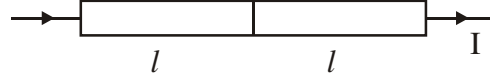

Figure - II

खण्ड - ग

Section - C

11. (a) किसी एकसमान चुम्बकीय क्षेत्र \vec{E} में स्थित द्विध्रुव आघूर्ण \vec{p} के द्विध्रुव पर कार्यरत बल-आघूर्ण की परिभाषा लिखिए । इसे सदिश रूप में व्यक्त कीजिए तथा इसके कार्य करने की दिशा निर्दिष्ट कीजिए ।
- (b) यदि यह क्षेत्र असमान हो तो क्या होगा ?
- (c) क्या होगा यदि बाह्य क्षेत्र \vec{E} में (i) \vec{p} के समान्तर, तथा (ii) \vec{p} के प्रति-समान्तर वृद्धि हो रही है ?
- (a) Define torque acting on a dipole of dipole moment \vec{p} placed in a uniform electric field \vec{E} . Express it in the vector form and point out the direction along which it acts.
- (b) What happens if the field is non-uniform ?
- (c) What would happen if the external field \vec{E} is increasing (i) parallel to \vec{p} and (ii) anti-parallel to \vec{p} ?

3

12. (a) v चाल से गतिमान कोई बिन्दुकित आवेश q किसी एकसमान चुम्बकीय क्षेत्र B , जो चित्र में दर्शाए अनुसार कागज के तल के भीतर की ओर कार्यरत है, में प्रवेश करता है। आवेश q द्वारा अपनाया गया पथ क्या है और यह किस तल में गति कर रहा है ?

3

(b) यदि आवेश के वेग का कोई अवयव \vec{B} के समान्तर है, तो आवेश द्वारा अपनाया गया पथ किस प्रकार प्रभावित होगा ?

(c) यदि इस कण पर कोई विद्युत क्षेत्र \vec{E} भी इस प्रकार अनुप्रयुक्त किया जाता है कि यह कण अपने मूल सरल रेखीय पथ पर ही गति करता रहे, तो विद्युत क्षेत्र \vec{E} का परिमाण और दिशा क्या होनी चाहिए ?

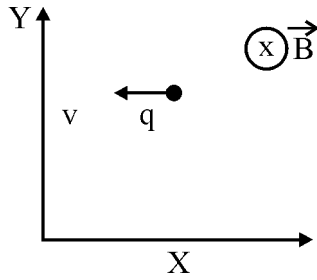

(a) A point charge q moving with speed v enters a uniform magnetic field B that is acting into the plane of the paper as shown. What is the path followed by the charge q and in which plane does it move ?

(b) How does the path followed by the charge get affected if its velocity has a component parallel to \vec{B} ?

(c) If an electric field \vec{E} is also applied such that the particle continues moving along the original straight line path, what should be the magnitude and direction of the electric field \vec{E} ?

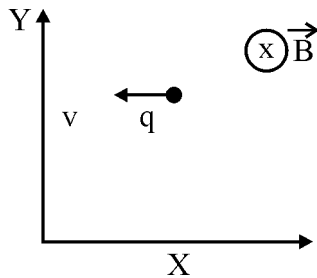

13. (i) वैद्युत-चुम्बकीय तरंगों के किस खण्ड की आवृत्ति अधिकतम होती है ? ये तरंगों किस प्रकार उत्पन्न होती हैं ? इन तरंगों का एक उपयोग लिखिए ।

(ii) कौन सी वैद्युत-चुम्बकीय तरंग वैद्युत-चुम्बकीय स्पेक्ट्रम के दृश्य भाग की उच्च आवृत्ति के समीप स्थित होती है ? इसका एक उपयोग लिखिए । प्रकाश का यह घटक किस प्रकार मानव पर हानिकर प्रभाव डालता है ?

3

(i) Which segment of electromagnetic waves has highest frequency ? How are these waves produced ? Give one use of these waves.

(ii) Which em waves lie near the high frequency end of visible part of em spectrum ? Give its one use. In what way this component of light has harmful effects on humans ?

14. नीचे दिए गए आरेख में कोई बिम्ब 'O' 20 cm फोकस दूरी के उत्तल लेंस L_1 के सामने 15 cm दूरी पर स्थित है और अंतिम प्रतिबिम्ब 'I' पर दूसरे लेंस L_2 से 80 cm दूरी पर बनता है । लेंस L_2 की फोकस दूरी ज्ञात कीजिए ।

3

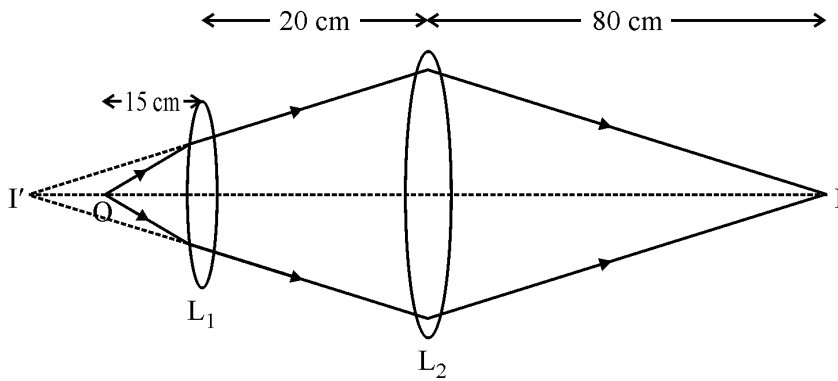

In the following diagram, an object 'O' is placed 15 cm in front of a convex lens L_1 of focal length 20 cm and the final image is formed at 'I' at a distance of 80 cm from the second lens L_2 . Find the focal length of the lens L_2 .

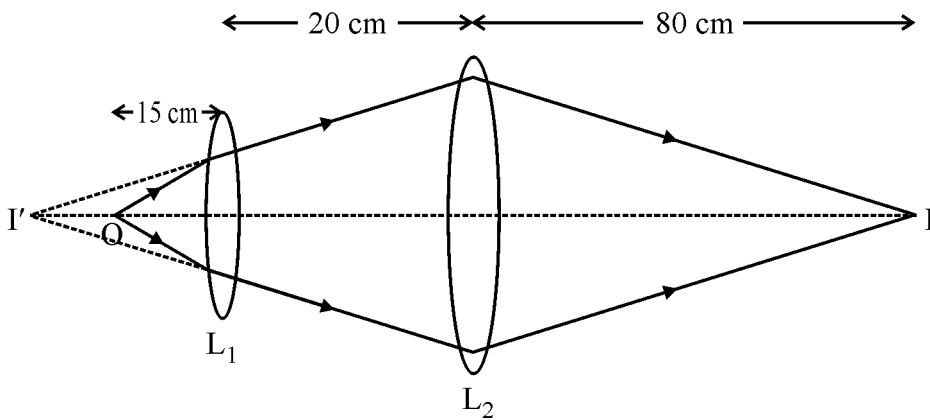

15. विभिन्न वर्णों की तीन प्रकाश किरणें (1, 2, 3) चित्र में दर्शाए अनुसार किसी समद्विबाहु समकोण त्रिभुज के एक फलक पर अभिलम्बवत आपतन करती हैं। इन किरणों के लिए प्रिज़म का अपवर्तनांक क्रमशः 1.39, 1.47 तथा 1.52 है। ज्ञात कीजिए, इनमें से कौन सी किरण आंतरिक परावर्तित होगी और कौन केवल फलक AC पर अपवर्तित होगी। इन किरणों का पथ आरेखित कीजिए। आवश्यक परिकलनों द्वारा अपने उत्तर की पुष्टि कीजिए।

3

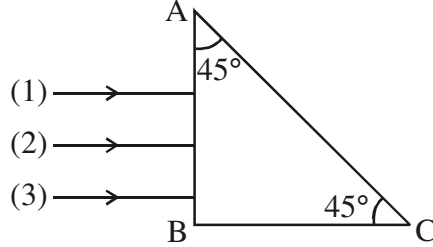

Three rays (1, 2, 3) of different colours fall normally on one of the sides of an isosceles right angled prism as shown. The refractive index of prism for these rays is 1.39, 1.47 and 1.52 respectively. Find which of these rays get internally reflected and which get only refracted from AC. Trace the paths of rays. Justify your answer with the help of necessary calculations.

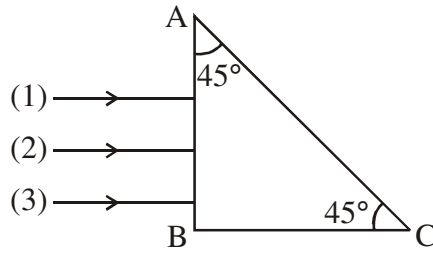

16. (i) सौर सेल के कार्यकारी सिद्धांत का वर्णन कीजिए। इसमें emf उत्पन्न होने में सम्मिलित तीन मूल प्रक्रियाओं का उल्लेख कीजिए।
- (ii) सौर-सेलों के लिए Si और GaAs प्राथमिकता दिए जाने वाले पदार्थ क्यों हैं ?
- (i) Describe the working principle of a solar cell. Mention three basic processes involved in the generation of emf.
- (ii) Why are Si and GaAs preferred materials for solar cells ?

3

17. नीचे दी गयी संधारित्रों की व्यवस्था में, $6 \mu\text{F}$ के संधारित्र में संचित ऊर्जा E है। निम्नलिखित का मान ज्ञात कीजिए :

- (i) $12 \mu\text{F}$ के संधारित्र में संचित ऊर्जा
- (ii) $3 \mu\text{F}$ के संधारित्र में संचित ऊर्जा
- (iii) बैटरी से ली गयी कुल ऊर्जा

3

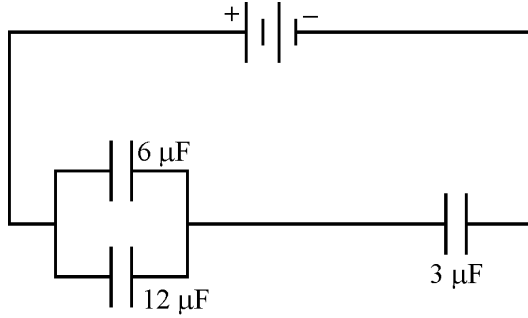

In the following arrangement of capacitors, the energy stored in the $6 \mu\text{F}$ capacitor is E . Find the value of the following :

- (i) Energy stored in $12 \mu\text{F}$ capacitor.
- (ii) Energy stored in $3 \mu\text{F}$ capacitor.
- (iii) Total energy drawn from the battery.

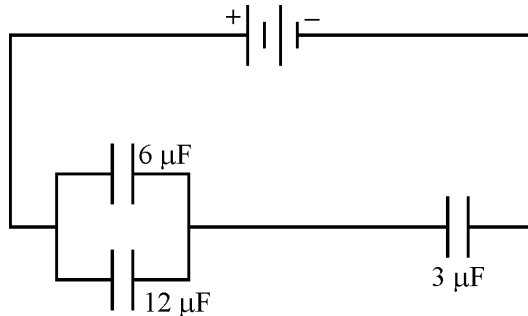

18. (i) रेडियोएक्टिव पदार्थ की 'सक्रियता' की परिभाषा लिखिए।
- (ii) T_1 और T_2 अर्ध-आयु वाले दो भिन्न रेडियोएक्टिव तत्वों में किसी दिए हुए समय पर क्रमशः N_1 और N_2 अक्षयित परमाणु उपस्थित हैं। उस समय पर इनकी सक्रियता के अनुपात का N_1 तथा N_2 के पदों में व्यंजक व्युत्पन्न कीजिए।

3

- (i) Define 'activity' of a radioactive substance.
- (ii) Two different radioactive elements with half lives T_1 and T_2 have N_1 and N_2 undecayed atoms respectively present at a given instant. Derive an expression for the ratio of their activities at this instant in terms of N_1 and N_2 .

19. प्रकाश की तीव्रता के साथ प्रकाश-विद्युत धारा के विचरण को दर्शाने के लिए ग्राफ खींचिए । नीचे दी गयी धातुओं के कार्यफलन इस प्रकार है :

Na : 2.75 eV तथा Mo : 4.175 eV

इनमें से कौन किसी लेसर पुन्ज से उत्पन्न 3300 Å तरंगदैर्घ्य के विकिरणों से प्रकाश-इलेक्ट्रॉन उत्सर्जन नहीं करेगा ? यदि लेसर पुन्ज के स्रोत को निकट लाएँ, तो क्या होगा ?

अथवा

प्रकाश-विद्युत उत्सर्जन में “अंतक आवृत्ति” की परिभाषा लिखिए । किसी धातु की देहली आवृत्ति f है । जब इस धातु की प्लेट पर $2f$ आवृत्ति का प्रकाश आपतित होता है, तब फोटो-इलेक्ट्रॉनों का अधिकतम वेग v_1 होता है । जब आपतित विकिरणों की आवृत्ति $5f$ कर दी जाती है, तब फोटो-इलेक्ट्रॉनों का अधिकतम वेग v_2 होता है । $v_1 : v_2$ ज्ञात कीजिए ।

3

Plot a graph showing the variation of photoelectric current with intensity of light. The work function for the following metals is given :

Na : 2.75 eV and Mo : 4.175 eV.

Which of these will not give photoelectron emission from a radiation of wavelength 3300 Å from a laser beam ? What happens if the source of laser beam is brought closer ?

OR

Define the term “cut off frequency” in photoelectric emission. The threshold frequency of a metal is f . When the light of frequency $2f$ is incident on the metal plate, the maximum velocity of photo-electrons is v_1 . When the frequency of the incident radiation is increased to $5f$, the maximum velocity of photo-electrons is v_2 . Find the ratio $v_1 : v_2$.

20. (a) बिन्दु से बिन्दु तक संचार तथा प्रसारण विधि द्वारा संचार में विभेदन कीजिए । प्रत्येक का एक उदाहरण दीजिए ।
- (b) मोबाइल टेलीफोनी की मूल अवधारणा की व्याख्या कीजिए ।
- (a) Distinguish between point to point and broadcast modes of communication. Give an example of each.
- (b) Explain the basic concept of mobile telephoning.

3

21. दो सर्वसम कुंडली P और Q जिनमें प्रत्येक की त्रिज्या R हैं, लम्बवत् तल में इस प्रकार रखे हैं कि इनके केन्द्र उभयनिष्ठ हैं । यदि इन पाशों से क्रमशः I तथा $\sqrt{3} I$ धाराएँ प्रवाहित होती हैं, तो इन दोनों के उभयनिष्ठ केन्द्र पर चुम्बकीय क्षेत्र का परिमाण और दिशा ज्ञात कीजिए ।

3

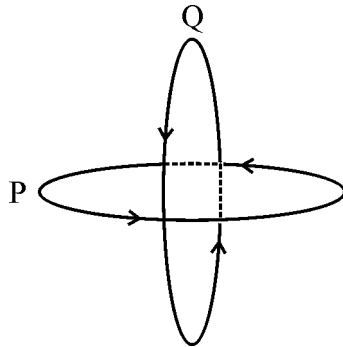

Two identical coils P and Q each of radius R are lying in perpendicular planes such that they have a common centre. Find the magnitude and direction of the magnetic field at the common centre of the two coils, if they carry currents equal to I and $\sqrt{3} I$ respectively.

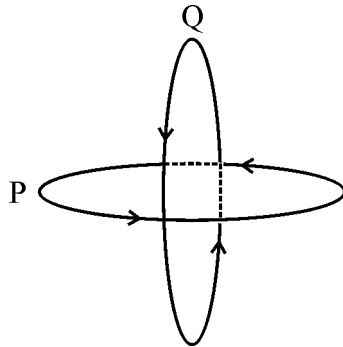

22. (i) स्वप्रेरकत्व की परिभाषा और इसका SI मात्रक लिखिए ।
- (ii) 15 फेरे प्रति सेन्टीमीटर वाली किसी लम्बी परिनालिका के भीतर 2.0 cm^2 क्षेत्रफल की छोटा पाश परिनालिका के अक्ष से अभिलम्बवत् रखा है । यदि परिनालिका से प्रवाहित धारा 0.1 s में 2.0 A से 4.0 A तक स्थायी रूप से परिवर्तित होती है, तब धारा में परिवर्तन के समय पाश में प्रेरित emf क्या है ?
- (i) Define self-inductance. Write its SI units.
- (ii) A long solenoid with 15 turns per cm has a small loop of area 2.0 cm^2 placed inside the solenoid normal to its axis. If the current carried by the solenoid changes steadily from 2.0 A to 4.0 A in 0.1 s, what is the induced emf in the loop while the current is changing ?

3

खण्ड – घ

Section – D

23. गौतम ग्रीष्मावकाश में अपनी दादी जी के गाँव गया । एक शाम उसकी दादी जी उसे “नौटंकी” दिखाने ले गयी । उन्होंने माइक्रोफोन के निकट एक काला बॉक्स, जो माइक्रोफोन से जुड़ा था, देखा । गौतम की दादी जी उस काले बॉक्स के बारे में नहीं जानती थीं । जब उन्होंने गौतम से उस बॉक्स के बारे में प्रश्न पूछा, तो उसने दादी जी को बताया कि यह प्रवर्धक है ।

- (i) उसकी दादी जी द्वारा कौन से मूल्य प्रदर्शित होते हैं ? विद्यार्थियों में इन मूल्यों को किस प्रकार स्थापित किया जा सकता है ?
- (ii) प्रवर्धक का क्या कार्य होता है ?
- (iii) प्रवर्धक में कौन सी मूल इलेक्ट्रॉनिक युक्ति उपयोग होती है ?

4

Gautam went for a vacation to the village where his grandmother lived. His grandmother took him to watch ‘nautanki’ one evening. They noticed a blackbox connected to the mike lying nearby. Gautam’s grandmother did not know what that box was. When she asked this question to Gautam, he explained to her that it was an amplifier.

- (i) Which values were displayed by the grandmother ? How can inculcation of these values in students be promoted ?
- (ii) What is the function of an amplifier ?
- (iii) Which basic electronic device is used in the amplifier ?

खण्ड – ङ

Section – E

24. (i) प्रकाश के विवर्तन के लिए आवश्यक शर्तें लिखिए ।
- (ii) किसी पतली एकल झिरी के कारण प्रकाश का विवर्तन और पर्दे पर फ्रिजों के पैटर्न बनने की व्याख्या कीजिए ।
- (iii) केन्द्रीय उच्चिष्ठ की चौड़ाई के लिए तरंगदैर्घ्य ‘ λ ’, झिरी की चौड़ाई ‘a’ तथा झिरी और पर्दे ‘D’ के बीच पृथक्कन, के पदों में संबंध प्राप्त कीजिए ।
- (iv) यदि झिरी की चौड़ाई मूल चौड़ाई की दो गुनी कर दी जाए, तो इसका केन्द्रीय बैण्ड की तीव्रता और साइज़ पर क्या प्रभाव पड़ेगा ?

5

अथवा

- (i) सामान्य समायोजन में खगोलीय दूरदर्शक की व्यवस्था का नामांकित आरेख खींचिए ।
- (ii) अपवर्ती दूरदर्शकों के अभिदृश्यकों में कौन से दो विपथन होते हैं ? परावर्ती दूरदर्शकों में इन्हें किस प्रकार दूर किया जाता है ?
- (iii) अभिदृश्यक लेंस के द्वारक में वृद्धि करने पर दूरदर्शक की विभेदन क्षमता किस प्रकार परिवर्तित होती है । अपने उत्तर की पुष्टि कीजिए ।
- (i) State the essential conditions for diffraction of light.
- (ii) Explain diffraction of light due to a narrow single slit and the formation of pattern of fringes on the screen.
- (iii) Find the relation for width of central maximum in terms of wavelength ' λ ', width of slit ' a ', and separation between slit and screen ' D '.
- (iv) If the width of the slit is made double the original width, how does it affect the size and intensity of the central band ?

OR

- (i) Draw a labelled schematic ray diagram of astronomical telescope in normal adjustment.
- (ii) Which two aberrations do objectives of refracting telescope suffer from ? How are these overcome in reflecting telescope ?
- (iii) How does the resolving power of a telescope change on increasing the aperture of the objective lens ? Justify your answer.

25. किसी AC स्रोत से $2 \mu\text{F}$ का संधारित्र, 100Ω का प्रतिरोधक तथा 8 H का प्रेरक श्रेणी में संयोजित हैं ।

- (i) स्रोत की आवृत्ति क्या होनी चाहिए ताकि परिपथ में अधिकतम धारा प्रवाहित हो ? इस आवृत्ति को क्या कहते हैं ?
- (ii) यदि स्रोत के e.m.f. का शिखर मान 200 V है, तो अधिकतम धारा ज्ञात कीजिए ।

- (iii) श्रेणीक्रम LRC परिपथ में विद्युत धारा के आयाम में परिवर्तन तथा अनुप्रयुक्त वोल्टता की परिवर्ती आवृत्ति के बीच दो पृथक प्रतिरोधों R_1 तथा R_2 ($R_1 > R_2$) के लिए ग्राफ खींचिए ।
- (iv) 'अनुनाद की तीक्ष्णता' की परिभाषा लिखिए । किन स्थितियों में कोई परिपथ अधिक वरणात्मक हो जाता है ?

5

अथवा

- (i) स्वच्छ व नामांकित आरेख की सहायता से चल कुण्डली गैल्वेनोमीटर का सिद्धान्त और कार्यविधि लिखिए ।
- (ii) एकसमान अरीय (त्रिज्य) क्षेत्र का क्या कार्य है और इसे किस प्रकार उत्पन्न किया जाता है ?
- (iii) गैल्वेनोमीटर की धारा सुग्राहिता की परिभाषा लिखिए । धारा सुग्राहिता में वृद्धि किस प्रकार की जाती है ?

A $2 \mu\text{F}$ capacitor, 100Ω resistor and 8 H inductor are connected in series with an AC source.

- (i) What should be the frequency of the source such that current drawn in the circuit is maximum ? What is this frequency called ?
- (ii) If the peak value of e.m.f. of the source is 200 V , find the maximum current.
- (iii) Draw a graph showing variation of amplitude of circuit current with changing frequency of applied voltage in a series LRC circuit for two different values of resistance R_1 and R_2 ($R_1 > R_2$).
- (iv) Define the term 'Sharpness of Resonance'. Under what condition, does a circuit become more selective ?

OR

- (i) With the help of a neat and labelled diagram, explain the principle and working of a moving coil galvanometer.
- (ii) What is the function of uniform radial field and how is it produced ?
- (iii) Define current sensitivity of a galvanometer. How is current sensitivity increased ?

26. (i) नीचे दिए गए परिपथ आरेख में AB कोई एकसमान तार है जिसकी लम्बाई 1 m तथा प्रतिरोध 15Ω है। यह नगण्य (उपेक्षणीय) आन्तरिक प्रतिरोध तथा एक प्रतिरोध R और 2V emf के सेल E_1 से संयोजित है। अन्य सेल E_2 , जिसका emf 75 mV है, के साथ सिरे A से 30 cm दूरी पर शून्य विक्षेप स्थिति प्राप्त होती है। R का मान ज्ञात कीजिए।

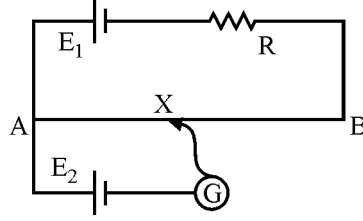

- (ii) सेलों के emf की तुलना के लिए वोल्टमीटर की अपेक्षा पोटेन्शियोमीटर को प्राथिकता क्यों दी जाती है ?
 (iii) प्रयोगशाला में सेल का आन्तरिक प्रतिरोध निर्धारित करने के लिए परिपथ आरेख खींचिए।

5

अथवा

- (i) वोल्टता और सेल से ली गयी धारा का विचरण दर्शाने के लिए ग्राफ खींचिए। इस ग्राफ से सेल की emf और उसके आन्तरिक प्रतिरोध के बारे में जानकारी कैसे प्राप्त की जा सकती है ?
 (ii) दो सेलों, जिनकी emf E_1 और E_2 तथा आन्तरिक प्रतिरोध r_1 तथा r_2 हैं, को पार्श्व में संयोजित किया गया है। इस संयोजन को प्रतिस्थापित करने वाले एकल सेल की emf और आन्तरिक प्रतिरोध के लिए व्यंजक प्राप्त कीजिए।
 (i) In the circuit diagram given below, AB is a uniform wire of resistance 15Ω and length 1 m. It is connected to a cell E_1 of emf 2V and negligible internal resistance and a resistance R. The balance point with another cell E_2 of emf 75 mV is found at 30 cm from end A. Calculate the value of R.

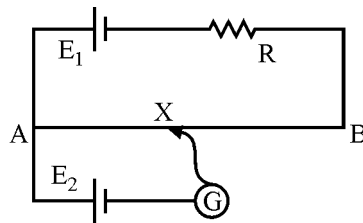

- (ii) Why is potentiometer preferred over a voltmeter for comparison of emf. of cells ?
 (iii) Draw a circuit diagram to determine internal resistance of a cell in the laboratory.

OR

- (i) Plot a graph showing variation of voltage vs the current drawn from the cell. How can one get information from this plot about the emf of the cell and its internal resistance ?
- (ii) Two cells of emf's E_1 and E_2 and internal resistance r_1 and r_2 are connected in parallel. Obtain the expression for the emf and internal resistance of a single equivalent cell that can replace this combination ?

MARKING SCHEME

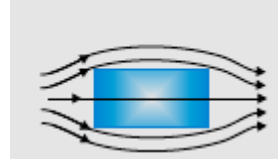
Q. No.	Expected Answer / Value Points SECTION -A	Marks	Total Marks																		
Set1,Q1 Set2,Q4 Set3,Q3	$V_A - V_B > 0$ $\Rightarrow V_A > V_B$ Q is positive (Even if a student writes the answer directly full marks to be given.)	$\frac{1}{2}$ $\frac{1}{2}$	1																		
Set1,Q2 Set2,Q5 Set3,Q4		1	1																		
Set1,Q3 Set2,Q1 Set3,Q5	$I_D = 0.25 A$	1	1																		
Set1,Q4 Set2,Q2 Set3,Q1	Any one of the following or any other (i) Magnetic braking in trains. (ii) Electromagnetic damping in certain galvanometers. (iii) Induction furnace to produce high temperature. (iv) Electric power meters (in which the disc rotates due to eddy currents.)	1	1																		
Set1,Q5 Set2,Q3 Set3,Q2	Electric flux $\Delta\phi$, through an area element $\overline{\Delta S}$, is defined by $\Delta\phi = \vec{E} \cdot \overline{\Delta S} = E\Delta S \cos\theta$ where θ is the angle between \vec{E} and $\overline{\Delta S}$. S.I unit of electric flux is $NC^{-1}m^2$. Alternatively, (Vm)	$\frac{1}{2}$ $\frac{1}{2}$	1																		
SECTION B																					
Set1,Q6 Set2,Q9 Set3,Q8	<table border="1" style="width: 100%; border-collapse: collapse;"> <tbody> <tr> <td style="padding: 5px;">(i) Bohr's (third) postulate</td> <td style="text-align: right; padding: 5px;">1</td> </tr> <tr> <td style="padding: 5px;">(ii) Number of spectral lines</td> <td style="text-align: right; padding: 5px;">$\frac{1}{2}$</td> </tr> <tr> <td style="padding: 5px;">Names of series</td> <td style="text-align: right; padding: 5px;">$\frac{1}{2}$</td> </tr> </tbody> </table> <p>(i) Bohr's (third) postulate: An electron might make a transition from one of its specified non- radiating orbits to another of lower energy. When it does so, a photon is emitted having energy equal to the energy difference between the initial and final states. The frequency of the emitted photon is given by $h\nu = E_i - E_f$</p> <p>(ii) Six spectral lines can be emitted.</p> <table style="margin-left: 20px;"> <tbody> <tr> <td style="padding: 2px 5px;">$4 \rightarrow 1$</td> <td rowspan="3" style="font-size: 2em; padding: 0 5px;">}</td> <td rowspan="3" style="padding: 0 5px;">Lyman series</td> </tr> <tr> <td style="padding: 2px 5px;">$3 \rightarrow 1$</td> </tr> <tr> <td style="padding: 2px 5px;">$2 \rightarrow 1$</td> </tr> <tr> <td style="padding: 2px 5px;">$4 \rightarrow 2$</td> <td rowspan="2" style="font-size: 2em; padding: 0 5px;">}</td> <td rowspan="2" style="padding: 0 5px;">Balmer series</td> </tr> <tr> <td style="padding: 2px 5px;">$3 \rightarrow 2$</td> </tr> <tr> <td style="padding: 2px 5px;">$4 \rightarrow 3$</td> <td></td> <td style="padding: 0 5px;">Paschen series</td> </tr> </tbody> </table>	(i) Bohr's (third) postulate	1	(ii) Number of spectral lines	$\frac{1}{2}$	Names of series	$\frac{1}{2}$	$4 \rightarrow 1$	}	Lyman series	$3 \rightarrow 1$	$2 \rightarrow 1$	$4 \rightarrow 2$	}	Balmer series	$3 \rightarrow 2$	$4 \rightarrow 3$		Paschen series	1 $\frac{1}{2}$ $\frac{1}{2}$	
(i) Bohr's (third) postulate	1																				
(ii) Number of spectral lines	$\frac{1}{2}$																				
Names of series	$\frac{1}{2}$																				
$4 \rightarrow 1$	}	Lyman series																			
$3 \rightarrow 1$																					
$2 \rightarrow 1$																					
$4 \rightarrow 2$	}	Balmer series																			
$3 \rightarrow 2$																					
$4 \rightarrow 3$		Paschen series																			

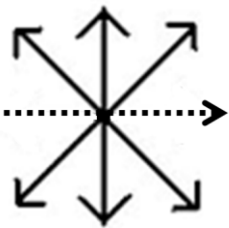
	 <p style="text-align: center;">Unpolarised</p> <p style="text-align: center;">Direction of Propagation</p> <p>Yes, it depends upon orientation of Polaroid because electric field vibrations , that are not in the direction of pass axis of Polaroid, are absorbed. Hence , intensity changes. (Alternatively,</p> $I = I_0 \cos^2 \theta$ <p>θ = angle between vibrations in light and axis of polaroid sheet)</p> $I = I_0 \cos^2 60^\circ = \frac{I_0}{4}$ $\Rightarrow \frac{I}{I_0} \times 100 = \frac{1}{4} \times 100 = 25\%$	<p style="text-align: center;">1/2</p> <p style="text-align: center;">1/2</p> <p style="text-align: center;">1/2</p> <p style="text-align: center;">2</p>	
<p>Set1,Q10 Set2,Q8 Set3,Q7</p>	<div style="border: 1px solid black; padding: 5px; margin-bottom: 10px;"> <p>Resistance of the two rod combination 1/2+ 1/2</p> <p>Calculation of potential difference 1</p> </div> $R_1 = \rho \frac{l}{A}$ $R_2 = \rho \frac{2l}{A/2} = 4R_1$ $I = \frac{V}{R_1} = \frac{V_2}{R_2}$ $\Rightarrow \frac{V}{R_1} = \frac{V_2}{4R_1}$ $\Rightarrow V_2 = 4V$	<p style="text-align: center;">1/2</p> <p style="text-align: center;">1/2</p> <p style="text-align: center;">1/2</p> <p style="text-align: center;">1/2</p>	<p style="text-align: center;">2</p>
SECTION C			
<p>Set1,Q11 Set2,Q19 Set3,Q16</p>	<div style="border: 1px solid black; padding: 5px; margin-bottom: 10px;"> <p>(a) Definition , Vector form and direction of torque 1/2+ 1/2</p> <p>(b)Effect of non uniform field 1</p> <p>(c) Effect of increasing field 1</p> </div> <p>a. $\tau = pE \sin \theta$; θ = angle between dipole moment(\vec{p}) and electric field(\vec{E}) $\vec{\tau} = \vec{p} \times \vec{E}$</p>	<p style="text-align: center;">1/2</p>	

Direction of torque is perpendicular to the plane containing \vec{p} and \vec{E} given by right hand screw rule.

(Alternatively,

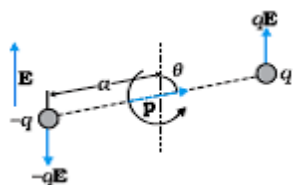

Direction of torque is out of the plane of the paper.)

b. If the field is non uniform the net force on the dipole will not be zero. There will be translatory motion of the dipole.

c.(i) Net force will be in the direction of increasing electric field.

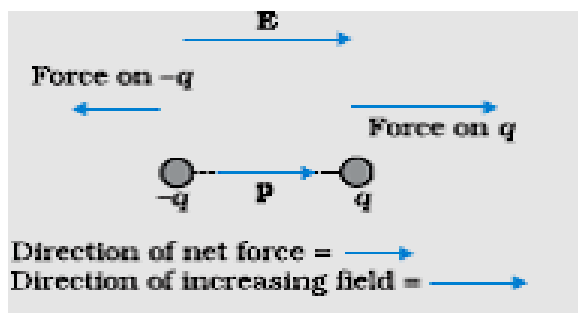

(ii) Net force will be in the direction opposite to the increasing field. [or in the direction of decreasing field]

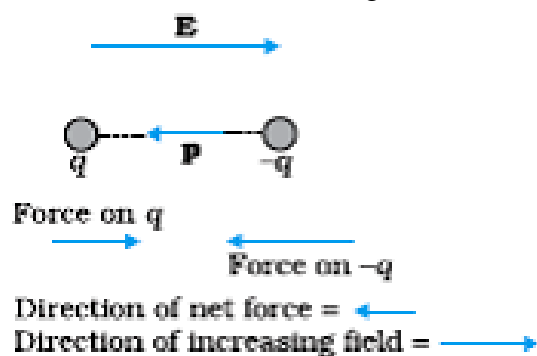

Set1,Q12 Set2,Q20 Set3,Q17	<table border="1"> <tbody> <tr> <td>(a) Nature and direction of path</td> <td>$\frac{1}{2} + \frac{1}{2}$</td> </tr> <tr> <td>(b) Nature of path</td> <td>$\frac{1}{2}$</td> </tr> <tr> <td>(c) Direction and magnitude of electric field</td> <td>$1 \frac{1}{2}$</td> </tr> </tbody> </table>	(a) Nature and direction of path	$\frac{1}{2} + \frac{1}{2}$	(b) Nature of path	$\frac{1}{2}$	(c) Direction and magnitude of electric field	$1 \frac{1}{2}$								
(a) Nature and direction of path	$\frac{1}{2} + \frac{1}{2}$														
(b) Nature of path	$\frac{1}{2}$														
(c) Direction and magnitude of electric field	$1 \frac{1}{2}$														
	<p>a. The charge q describes a circular path ; anticlockwise in XY plane.</p> <p>b. The path will become helical.</p> <p>c. Direction of Lorentz magnetic force is $-Y$ \therefore Applied electric field should be in $+Y$ direction . $F_E = F_m$ $\Rightarrow qE = qvB$ $\Rightarrow E = vB$</p>	<p>$\frac{1}{2} + \frac{1}{2}$</p> <p>$\frac{1}{2}$</p> <p>$\frac{1}{2}$</p> <p>$\frac{1}{2}$</p> <p>$\frac{1}{2}$</p>	3												
Set1,Q13 Set2,Q21 Set3,Q18	<table border="1"> <tbody> <tr> <td>(i) Highest frequency segment</td> <td>$\frac{1}{2}$</td> </tr> <tr> <td>Production of waves</td> <td>$\frac{1}{2}$</td> </tr> <tr> <td>One use of waves</td> <td>$\frac{1}{2}$</td> </tr> <tr> <td>(ii) Segment near high frequency end of visible</td> <td>$\frac{1}{2}$</td> </tr> <tr> <td>One use of this segment</td> <td>$\frac{1}{2}$</td> </tr> <tr> <td>Its harmful effect</td> <td>$\frac{1}{2}$</td> </tr> </tbody> </table>	(i) Highest frequency segment	$\frac{1}{2}$	Production of waves	$\frac{1}{2}$	One use of waves	$\frac{1}{2}$	(ii) Segment near high frequency end of visible	$\frac{1}{2}$	One use of this segment	$\frac{1}{2}$	Its harmful effect	$\frac{1}{2}$		
(i) Highest frequency segment	$\frac{1}{2}$														
Production of waves	$\frac{1}{2}$														
One use of waves	$\frac{1}{2}$														
(ii) Segment near high frequency end of visible	$\frac{1}{2}$														
One use of this segment	$\frac{1}{2}$														
Its harmful effect	$\frac{1}{2}$														
	<p>(i) γ rays.</p> <p>Produced in nuclear reactions and emitted by radioactive decay of nucleus.</p> <p>Used in medicine to destroy cancer cells.</p> <p>(ii) Ultra violet rays Used in LASIK eye surgery , UV lamps to kill germs in water purifier (any one use or any other) Causes sunburn / skin cancer / harms eyes when exposed to direct UV rays (any one)</p>	<p>$\frac{1}{2}$</p> <p>$\frac{1}{2}$</p> <p>$\frac{1}{2}$</p> <p>$\frac{1}{2}$</p> <p>$\frac{1}{2}$</p> <p>$\frac{1}{2}$</p>	3												
Set1,Q14 Set2,Q22 Set3,Q19	<table border="1"> <tbody> <tr> <td>Lens formula</td> <td>$\frac{1}{2}$</td> </tr> <tr> <td>Image distance for L_1</td> <td>1</td> </tr> <tr> <td>Object distance for L_2</td> <td>$\frac{1}{2}$</td> </tr> <tr> <td>Focal length of L_2</td> <td>1</td> </tr> </tbody> </table>	Lens formula	$\frac{1}{2}$	Image distance for L_1	1	Object distance for L_2	$\frac{1}{2}$	Focal length of L_2	1						
Lens formula	$\frac{1}{2}$														
Image distance for L_1	1														
Object distance for L_2	$\frac{1}{2}$														
Focal length of L_2	1														

	<p>For L_1</p> $\frac{1}{v_1} - \frac{1}{u_1} = \frac{1}{f_1}$ $\Rightarrow \frac{1}{v_1} = \frac{1}{20} - \frac{1}{15} = -\frac{1}{60}$ $\Rightarrow v_1 = -60 \text{ cm}$ <p>For lens L_2 $u = (-20 - 60)\text{cm} = -80 \text{ cm}$ $v = 80 \text{ cm}$ $\therefore u = v = 2 f_2$ $\Rightarrow f_2 = \frac{80}{2} = 40 \text{ cm}$</p>	<p>$\frac{1}{2}$</p> <p>1</p> <p>$\frac{1}{2}$</p> <p>$\frac{1}{2}$</p> <p>$\frac{1}{2}$</p>	<p>3</p>								
<p>Set1,Q15 Set2,Q11 Set3,Q20</p>	<table border="1" style="width: 100%; border-collapse: collapse;"> <tbody> <tr> <td style="padding: 5px;">Condition for TIR</td> <td style="text-align: right; padding: 5px;">$\frac{1}{2}$</td> </tr> <tr> <td style="padding: 5px;">Value of μ for TIR</td> <td style="text-align: right; padding: 5px;">1</td> </tr> <tr> <td style="padding: 5px;">Conclusion for rays 1,2,3</td> <td style="text-align: right; padding: 5px;">1</td> </tr> <tr> <td style="padding: 5px;">Ray diagram</td> <td style="text-align: right; padding: 5px;">$\frac{1}{2}$</td> </tr> </tbody> </table> <p>$i = 45^\circ$ (on face AC)</p> <p>For TIR $i > i_c$ $\Rightarrow \sin i > \sin i_c$ $\Rightarrow \frac{1}{\sin i} < \frac{1}{\sin i_c}$ $\Rightarrow \mu > \frac{1}{\sin i} \qquad \because \mu = \frac{1}{\sin i_c}$</p> <p>$\mu > \sqrt{2} = 1.414$ for TIR \therefore Ray (1) is refracted from AC And rays (2) and (3) are internally reflected.</p> <div style="text-align: center;"> </div>	Condition for TIR	$\frac{1}{2}$	Value of μ for TIR	1	Conclusion for rays 1,2,3	1	Ray diagram	$\frac{1}{2}$	<p>$\frac{1}{2}$</p> <p>1</p> <p>1</p> <p>$\frac{1}{2}$</p>	<p>3</p>
Condition for TIR	$\frac{1}{2}$										
Value of μ for TIR	1										
Conclusion for rays 1,2,3	1										
Ray diagram	$\frac{1}{2}$										

Set1,Q16 Set2,Q12 Set3,Q21	<table border="1" style="margin-left: auto; margin-right: auto;"> <tbody> <tr> <td>(i)</td> <td>Working principle of solar cell</td> <td>1</td> </tr> <tr> <td></td> <td>Three basic processes</td> <td>1</td> </tr> <tr> <td>(ii)</td> <td>Why Si and GaAs are preferred materials?</td> <td>1</td> </tr> </tbody> </table> <p>(i) When solar cell is illuminated with light photons of energy ($h\nu$) greater than the energy gap (E_g) of the semiconductor, then electron hole pairs are generated due to absorption of photons.</p> <p>The three basic processes involved in the generation of emf :</p> <p>(a) generation of e-h pairs due to light (with $h\nu > E_g$) close to the junction ;</p> <p>(b) separation of electrons and holes due to electric field of the depletion region</p> <p>(c) the electrons reaching the n side are collected by the front contact and holes reaching p side are collected by back contact,</p> <p>(ii) Solar radiation has maximum intensity of photons of energy = 1.5eV</p> <p>Hence semiconducting materials Si and GaAs, with band gap ≈ 1.5 eV, are preferred materials for solar cells.</p>	(i)	Working principle of solar cell	1		Three basic processes	1	(ii)	Why Si and GaAs are preferred materials?	1	<p>1</p> <p>1</p> <p>1</p> <p>1</p> <p>1</p>	<p>3</p>
(i)	Working principle of solar cell	1										
	Three basic processes	1										
(ii)	Why Si and GaAs are preferred materials?	1										
Set1,Q17 Set2,Q13 Set3,Q22	<table border="1" style="margin-left: auto; margin-right: auto;"> <tbody> <tr> <td>Energy stored in $12\mu\text{f}$ capacitor</td> <td>1</td> </tr> <tr> <td>Energy stored in $3\mu\text{f}$ capacitor</td> <td>$1\frac{1}{2}$</td> </tr> <tr> <td>Total energy drawn from battery</td> <td>$\frac{1}{2}$</td> </tr> </tbody> </table> <p>(i) $E = \frac{1}{2}CV^2 = \frac{6}{2} \times 10^{-6}V^2 = 3 \times 10^{-6}V^2$ $\therefore V^2 = \frac{E}{3 \times 10^{-6}}$</p> <p>Energy stored in $12\mu\text{f}$ capacitor $= \frac{1}{2}CV^2$ $= \frac{1}{2} \times 12 \times 10^{-6} \times \frac{E}{3 \times 10^{-6}}$ $= 2E$</p> <p>(ii) Charge on $6\mu\text{f}$ capacitor, $Q_1 = \sqrt{2EC} \left[\because E = \frac{1}{2} \frac{Q^2}{C} \right]$ $= 2\sqrt{3E} \times 10^{-3}C$</p> <p>Charge on $12\mu\text{f}$ capacitor, $Q_2 = \sqrt{2CE}$ $= \sqrt{2 \times 12 \times 10^{-6} \times 2E}$</p>	Energy stored in $12\mu\text{f}$ capacitor	1	Energy stored in $3\mu\text{f}$ capacitor	$1\frac{1}{2}$	Total energy drawn from battery	$\frac{1}{2}$	<p>$\frac{1}{2}$</p> <p>$\frac{1}{2}$</p> <p>$\frac{1}{2}$</p>				
Energy stored in $12\mu\text{f}$ capacitor	1											
Energy stored in $3\mu\text{f}$ capacitor	$1\frac{1}{2}$											
Total energy drawn from battery	$\frac{1}{2}$											

	$= 4\sqrt{3E}10^{-3}C$ <p>Charge on 3 μf capacitor, $Q = Q_1 + Q_2$</p> $= 6\sqrt{3E}10^{-3}$ <p>Energy stored in 3 μf capacitor $= \frac{1}{2} \frac{Q^2}{C} = \frac{1}{2} \frac{36 \times 3E \times 10^{-6}}{3 \times 10^{-6}}$</p> $= 18E$ <p>(Alternatively:</p> <p>(ii) capacitance of parallel combination = 18 μf</p> <p>Charge on parallel combination, $Q = CV$</p> $= 18 \times 10^{-6}V$ <p>Charge on 3 $\mu f = Q = 3 \times 10^{-6}V_1$</p> $(\Rightarrow) 18 \times 10^{-6}V = 3 \times 10^{-6}V_1$ $(\Rightarrow) V_1 = 6V$ <p>\therefore Energy stored in 3 μf capacitor $= \frac{1}{2} CV_1^2$</p> $= \frac{1}{2} \times 3 \times 10^{-6} \times \frac{E \times 36}{3 \times 10^{-6}}$ $= 18E)$ <p>(iii) Total energy drawn = $E + 2E + 18E = 21E$</p>	<p>$\frac{1}{2}$</p> <p>$\frac{1}{2}$</p> <p>$\frac{1}{2}$</p> <p>$\frac{1}{2}$</p> <p>$\frac{1}{2}$</p> <p>$\frac{1}{2}$</p>	<p>3</p>				
<p>Set1,Q18 Set2,Q14 Set3,Q11</p>	<table border="1" data-bbox="354 1024 1182 1119"> <tbody> <tr> <td>(i) Definition of activity</td> <td>1</td> </tr> <tr> <td>(ii) Derivation</td> <td>2</td> </tr> </tbody> </table> <p>(i) Number of radioactive nuclei decaying per second at any time. 1</p> <p>(ii) $R_1 = \lambda_1 N_1 = \frac{0.693}{T_1} N_1$ $\frac{1}{2}$</p> $R_2 = \lambda_2 N_2 = \frac{0.693}{T_2} N_2$ $\frac{1}{2}$ $\frac{R_1}{R_2} = \frac{N_1}{N_2} \times \frac{T_2}{T_1}$ 1	(i) Definition of activity	1	(ii) Derivation	2	<p>1</p> <p>$\frac{1}{2}$</p> <p>$\frac{1}{2}$</p> <p>1</p>	<p>3</p>
(i) Definition of activity	1						
(ii) Derivation	2						
<p>Set1,Q19 Set2,Q15 Set3,Q12</p>	<table border="1" data-bbox="358 1545 1177 1640"> <tbody> <tr> <td>Graph of photocurrent with intensity</td> <td>1</td> </tr> <tr> <td>Numerical</td> <td>2</td> </tr> </tbody> </table> <p>(i)</p>	Graph of photocurrent with intensity	1	Numerical	2		
Graph of photocurrent with intensity	1						
Numerical	2						

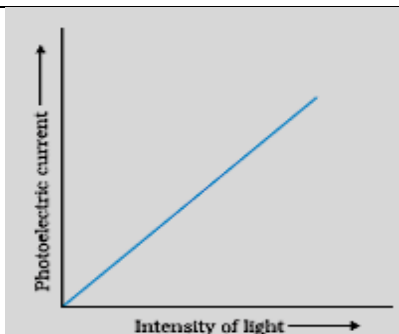

(ii) Energy of a photon $E = \frac{hc}{\lambda}$ Joule

$$= \frac{hc}{e\lambda} \text{ eV}$$

$$= \frac{6.63 \times 10^{-34} \times 3 \times 10^8}{1.6 \times 10^{-19} \times 3.3 \times 10^{-7}} \text{ eV}$$

$$= 3.75 \text{ eV}$$

Since W_0 of M_0 is greater than E , $\therefore M_0$ will not give photoemission. There will be no effect of bringing source closer in the case of M_0 . In case of Na, photocurrent will increase.

OR

Definition of cut off frequency	1
Finding ratio $\frac{v_1}{v_2}$	2

Cut off frequency : It is that maximum frequency of incident radiation below which no photo emission takes place from a photo electric material.

(**Alternatively**, That minimum frequency of incident radiation at which photons are just emitted with zero kinetic energy.)

$$K_{max} = hf - W_0$$

$$\frac{1}{2}mv_1^2 = 2hf - hf = hf$$

$$\frac{1}{2}mv_2^2 = 5hf - hf = 4hf$$

$$\therefore \frac{v_1^2}{v_2^2} = \frac{1}{4}$$

$$\Rightarrow \frac{v_1}{v_2} = \frac{1}{2}$$

1

 $\frac{1}{2}$ $\frac{1}{2}$ $\frac{1}{2}$ $\frac{1}{2}$

3

1

 $\frac{1}{2}$ $\frac{1}{2}$ $\frac{1}{2}$ $\frac{1}{2}$

3

	$B_p = \frac{\mu_0}{4\pi} \cdot \frac{2\pi I}{R}$ $B_Q = \frac{\mu_0}{4\pi} \cdot \frac{2\pi(\sqrt{3}I)}{R}$ $B = \sqrt{B_p^2 + B_Q^2}$ $= \frac{\mu_0}{4\pi} \cdot \frac{2\pi I}{R} \sqrt{1+3}$ $= \frac{\mu_0 I}{R}$ $\tan \theta = \frac{B_p}{B_Q} = \frac{1}{\sqrt{3}}$ $\Rightarrow \theta = 30^\circ$	<p>1/2</p> <p>1/2</p> <p>1/2</p> <p>1/2</p> <p>1/2</p> <p>3</p>													
<p>Set1,Q22 Set2,Q18 Set3,Q15</p>	<table border="1" style="width: 100%; border-collapse: collapse;"> <tbody> <tr> <td style="width: 5%;">(i)</td> <td style="width: 65%;">Definition and unit</td> <td style="width: 30%;">1/2 + 1/2</td> </tr> <tr> <td>(ii)</td> <td>Formula – Magnetic field inside solenoid</td> <td>1/2</td> </tr> <tr> <td></td> <td>Formula – Induced emf in loop</td> <td>1/2</td> </tr> <tr> <td></td> <td>Calculation of induced emf in loop</td> <td>1</td> </tr> </tbody> </table> <p>(i) Self inductance is the amount of magnetic flux linked with a coil when a unit current flows through it. (Alternatively , It is the amount of emf induced in a coil when current through it changes at the rate of 1 A per second.)</p> <p>S.I. unit : henry(H)</p> <p>(ii) Magnetic field inside the solenoid , $B = \mu_0 n I$ Induced emf in the loop , $\epsilon = \frac{d\phi_B}{dt}$</p> $= A \frac{dB}{dt}$ $= \mu_0 n A \frac{dI}{dt}$ $= 4\pi \times 10^{-7} \times 1500 \times 2 \times 10^{-4} \times \frac{(4-2)}{0.1} V$ $= 7.5 \times 10^{-6} V$	(i)	Definition and unit	1/2 + 1/2	(ii)	Formula – Magnetic field inside solenoid	1/2		Formula – Induced emf in loop	1/2		Calculation of induced emf in loop	1	<p>1/2</p> <p>1/2</p> <p>1/2</p> <p>1</p> <p>3</p>	
(i)	Definition and unit	1/2 + 1/2													
(ii)	Formula – Magnetic field inside solenoid	1/2													
	Formula – Induced emf in loop	1/2													
	Calculation of induced emf in loop	1													

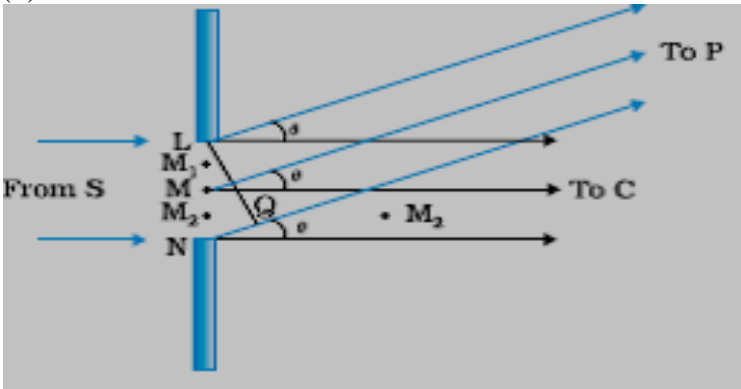
<p>Set1,Q23 Set2,Q23 Set3,Q23</p>	<p style="text-align: center;">SECTION D</p> <table border="1" style="margin-left: auto; margin-right: auto;"> <tbody> <tr> <td>(i)</td> <td>Values displayed (any two)</td> <td>$\frac{1}{2} + \frac{1}{2}$</td> </tr> <tr> <td></td> <td>Inculcation of these values</td> <td>1</td> </tr> <tr> <td>(ii)</td> <td>Function of amplifier</td> <td>1</td> </tr> <tr> <td>(iii)</td> <td>Name of device</td> <td>1</td> </tr> </tbody> </table> <p>(i) Inquisitive , loving , scientific temperament (or any other two values) By encouraging students to ask questions . By giving them tasks / projects and allowing students to use different media to find the solution to the given task, (any other)</p> <p>(ii) It is a device which produces an amplified copy of the signal.</p> <p>(iii) Transistor.</p>	(i)	Values displayed (any two)	$\frac{1}{2} + \frac{1}{2}$		Inculcation of these values	1	(ii)	Function of amplifier	1	(iii)	Name of device	1	<p>$\frac{1}{2} + \frac{1}{2}$</p> <p>$\frac{1}{2} + \frac{1}{2}$</p> <p>1</p> <p>1</p>	<p style="text-align: center;">4</p>
(i)	Values displayed (any two)	$\frac{1}{2} + \frac{1}{2}$													
	Inculcation of these values	1													
(ii)	Function of amplifier	1													
(iii)	Name of device	1													
<p>Set1,Q24 Set2,Q26 Set3,Q25</p>	<p style="text-align: center;">SECTION E</p> <table border="1" style="margin-left: auto; margin-right: auto;"> <tbody> <tr> <td>(i)</td> <td>Condition for diffraction</td> <td>$\frac{1}{2}$</td> </tr> <tr> <td>(ii)</td> <td>Diagram and explanation of fringe pattern</td> <td>$1 + 1\frac{1}{2}$</td> </tr> <tr> <td>(iii)</td> <td>Derivation of width of central maxima</td> <td>1</td> </tr> <tr> <td>(iv)</td> <td>Effect on size and intensity of central maxima</td> <td>$\frac{1}{2} + \frac{1}{2}$</td> </tr> </tbody> </table> <p>(i) Size of slit / aperture must be smaller than of the order of wavelength of light.</p> <p>(ii)</p>  <p>Single slit diffraction is explained by treating different parts of the wavefront at the slit as sources of secondary wavelets. At the central point C on the screen , θ is zero . All path differences are zero</p>	(i)	Condition for diffraction	$\frac{1}{2}$	(ii)	Diagram and explanation of fringe pattern	$1 + 1\frac{1}{2}$	(iii)	Derivation of width of central maxima	1	(iv)	Effect on size and intensity of central maxima	$\frac{1}{2} + \frac{1}{2}$	<p>$\frac{1}{2}$</p> <p>1</p> <p>$\frac{1}{2}$</p>	
(i)	Condition for diffraction	$\frac{1}{2}$													
(ii)	Diagram and explanation of fringe pattern	$1 + 1\frac{1}{2}$													
(iii)	Derivation of width of central maxima	1													
(iv)	Effect on size and intensity of central maxima	$\frac{1}{2} + \frac{1}{2}$													

and hence all the parts of the slit contribute in phase and give maximum intensity at C.

At any other point P , the path difference between two edges of the slit is $NP - LP = NQ$

$$= a \sin\theta \approx a\theta$$

Any point P , in direction θ , is a location of minima if $a\theta = n\lambda$

This can be explained by dividing the slit into even number of parts. The path difference between waves from successive parts is 180° out of phase and hence cancel each other leading to a minima.

1/2

Any point P , in direction Q , is a location of maxima if $a\theta = \left(n + \frac{1}{2}\right)\lambda$

This can be explained by dividing the slit into odd number of parts. The contributions from successive parts cancel in pairs because of 180° phase difference .The unpaired part produces intensity at P , leading to a maxima.

1/2

(iii) If θ is the direction of first minima , then $a\theta = \lambda \Rightarrow \theta = \frac{\lambda}{a}$

$$\begin{aligned} \text{Angular width of central maxima} &= 2\theta \\ &= \frac{2\lambda}{a} \end{aligned}$$

1/2

$$\begin{aligned} \text{Linear width of central maxima, } \beta &= 2\theta \cdot D \\ &= \frac{2\lambda D}{a} \end{aligned}$$

1/2

(iv) If 'a' is doubled , β becomes half
Intensity becomes 4 times.

1/2

1/2

OR

Diagram of telescope	2
Two aberration	1/2+ 1/2
Overcoming aberrations	1/2+ 1/2
Expression for resolving power and change	1/2+ 1/2

5

(i)

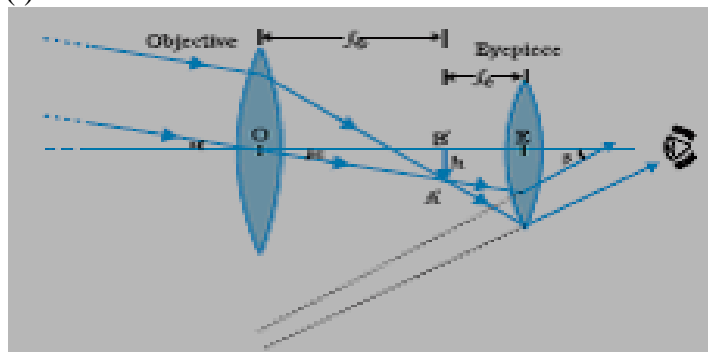

2

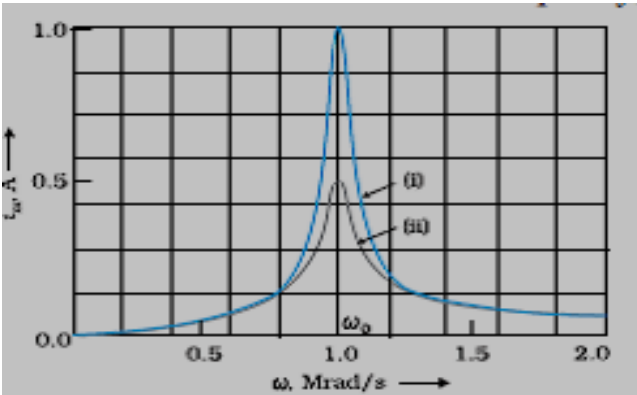
	<p>(ii) Spherical aberration . It can be corrected by using parabolic mirror objective. Chromatic aberration. By using mirrors instead of spherical lenses because mirrors do not suffer from chromatic aberration.</p> <p>(iii) $RP = \frac{a}{0.61\lambda}$</p> <p>On increasing aperture 'a' , RP also increases.</p>	<p>$\frac{1}{2} + \frac{1}{2}$</p> <p>$\frac{1}{2} + \frac{1}{2}$</p> <p>$\frac{1}{2}$</p> <p>$\frac{1}{2}$</p>	<p>5</p>																		
<p>Set1,Q25 Set2,Q24 Set3,Q26</p>	<table border="1" data-bbox="324 745 1205 978"> <tbody> <tr> <td>(i)</td> <td>Frequency at maximum current</td> <td>1</td> </tr> <tr> <td></td> <td>Name of frequency</td> <td>$\frac{1}{2}$</td> </tr> <tr> <td>(ii)</td> <td>Maximum current</td> <td>1</td> </tr> <tr> <td>(iii)</td> <td>Graph</td> <td>1</td> </tr> <tr> <td>(iv)</td> <td>Definition of sharpness of resonance</td> <td>1</td> </tr> <tr> <td></td> <td>Condition</td> <td>$\frac{1}{2}$</td> </tr> </tbody> </table> <p>(i) $\omega_0 = \frac{1}{\sqrt{LC}} = \frac{1}{\sqrt{8 \times 2 \times 10^{-6}}} = 250 \text{ rad / s}$ or $f_0 = \frac{\omega_0}{2\pi} = \frac{125}{\pi} \text{ Hz}$</p> <p>Resonant frequency</p> <p>(ii) $I_{max} = \frac{V_0}{R} = \frac{200}{100} A = 2A$</p> <p>(iii)</p>  <p>(iv) $\frac{\omega_0}{2\Delta\omega}$ is measure of sharpness of resonance , where ω_0 is the resonant frequency and $2\Delta\omega$ is the bandwidth.</p>	(i)	Frequency at maximum current	1		Name of frequency	$\frac{1}{2}$	(ii)	Maximum current	1	(iii)	Graph	1	(iv)	Definition of sharpness of resonance	1		Condition	$\frac{1}{2}$	<p>1</p> <p>$\frac{1}{2}$</p> <p>1</p> <p>1</p>	
(i)	Frequency at maximum current	1																			
	Name of frequency	$\frac{1}{2}$																			
(ii)	Maximum current	1																			
(iii)	Graph	1																			
(iv)	Definition of sharpness of resonance	1																			
	Condition	$\frac{1}{2}$																			

Circuit is more selective if it has greater value of sharpness / The circuit should have smaller band width $\Delta\omega$.

1/2

5

OR

- | | | |
|-------|--|-------------|
| (i) | Principle , diagram , theory of galvanometer | 1/2+1+1 1/2 |
| (ii) | Function of radial field , its production | 1/2 + 1/2 |
| (iii) | Current sensitivity , how it is increased | 1/2 + 1/2 |

(i) A current carrying loop experience a torque in a magnetic field.

1/2

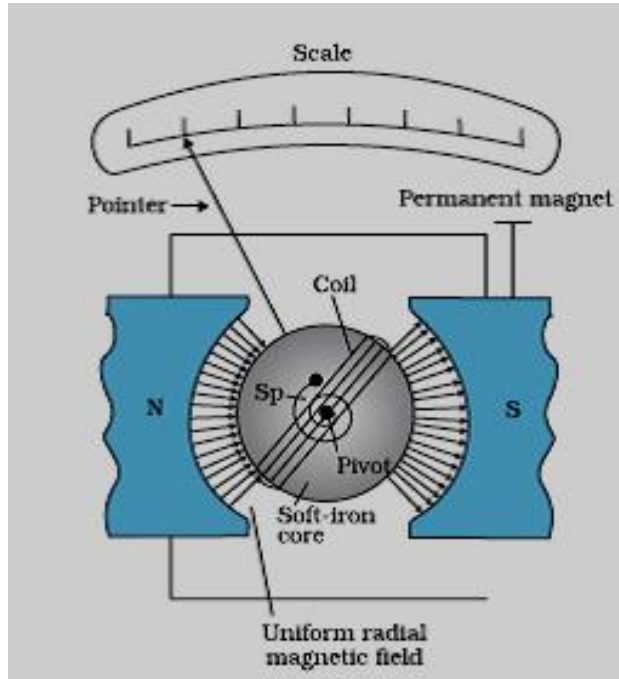

1

Torque on the current coil , $\tau = NIAB \sin 90^\circ$ (in radial field)

1/2

Counter torque provided by the spring = $k\phi$ where ϕ is the deflection of the coil and k is torsional constant of the spring.

1/2

At equilibrium ,

$$k\phi = NIAB$$

$$\Rightarrow \phi = \left(\frac{NAB}{K}\right) I$$

1/2

(ii) Radial field makes the scale of galvanometer linear or $I \propto \phi$
It is produced by making pole pieces of the magnet cylindrical in shape.

1/2

1/2

(ii) Current sensitivity is defined as current per unit deflection.
Current sensitivity is increased by increasing the number of turns N.

1/2

1/2

5

Set1,Q26
Set2,Q25
Set3,Q24

(i)	Calculation of R	2 ½
(ii)	Preference of potentiometer over voltmeter	1
(iii)	Circuit diagram	1 ½

(i) Current through AB

$$I = \frac{\epsilon_1}{R + R_{AB}} = \frac{2}{R + 15}$$

½

P.D. across AB, $V_{AB} = IR_{AB}$

$$= \left(\frac{2}{R + 15} \right) \cdot 15$$

½

$$\text{Potential gradient } k = \frac{V_{AB}}{AB} = \frac{30}{(R+15) \times 100}$$

$$= \frac{0.3}{R + 15}$$

½

Balance length for cell $E_2 (= 75\text{mV})$, $l = \frac{E_2}{k}$

$$\Rightarrow 30 = \frac{75 \times 10^{-3} (R + 15)}{0.3}$$

½

$$\Rightarrow \frac{9 \times 10^3}{75} = R + 15$$

$$\Rightarrow R = 105 \Omega$$

½

(ii) A potentiometer is preferred over a voltmeter because potentiometer does not draw current for any measurement unlike a voltmeter.

1

(**Alternatively**, Potentiometer compares the emf values while the voltmeter would only compare the terminal p.d.'s of the two cells.)

(iii)

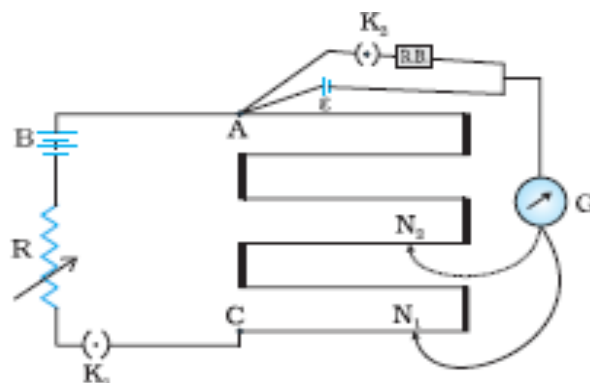

1 ½

5

OR

(i)	Graph of V vs I	1
	Emf	1/2
	Internal resistance	1/2
(ii)	Diagram	1
	Derivation of E and Internal resistance	1

(i)

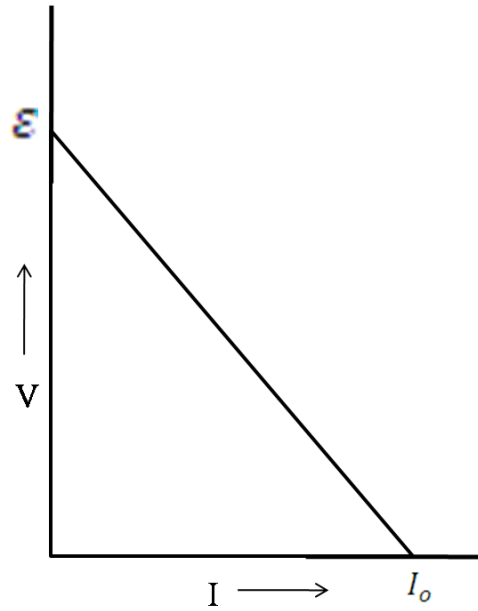

$$V = \epsilon - Ir$$

When current is zero ($I=0$), $V = \epsilon$

And when $V=0$, $I = I_0$, $r = \frac{\epsilon}{I_0}$

(ii)

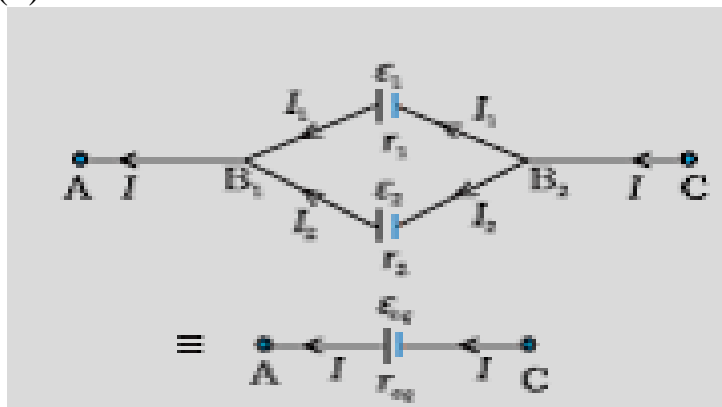

1

1/2

1/2

1

	$V = V(B_1) - V(B_2) = \varepsilon_1 - I_1 r_1$ $V = V(B_1) - V(B_2) = \varepsilon_2 - I_2 r_2$ $I = I_1 + I_2$ $= \frac{\varepsilon_1 - V}{r_1} + \frac{\varepsilon_2 - V}{r_2} = \left(\frac{\varepsilon_1 + \varepsilon_2}{r_1 + r_2} \right) - V \left(\frac{1}{r_1} + \frac{1}{r_2} \right)$ $V = \frac{\varepsilon_1 r_2 + \varepsilon_2 r_1}{r_1 + r_2} - I \frac{r_1 r_2}{r_1 + r_2}$ <p>On comparing with</p> $V = \varepsilon_{\text{eq}} - I r_{\text{eq}}$ <p>we get</p> $\varepsilon_{\text{eq}} = \frac{\varepsilon_1 r_2 + \varepsilon_2 r_1}{r_1 + r_2}$ $r_{\text{eq}} = \frac{r_1 r_2}{r_1 + r_2}$ <p>(Alternatively , a student may write the last two results in the following form.</p> $\frac{1}{r_{\text{eq}}} = \frac{1}{r_1} + \frac{1}{r_2}$ $\frac{\varepsilon_{\text{eq}}}{r_{\text{eq}}} = \frac{\varepsilon_1}{r_1} + \frac{\varepsilon_2}{r_2})$	<p>1/2</p> <p>1/2</p> <p>1/2</p> <p>1/2</p>	<p>5</p>
--	--	---	----------