

FINAL JEE-MAIN EXAMINATION – AUGUST, 2021

(Held On Tuesday 31st August, 2021)

TIME : 9 : 00 AM to 12 : 00 NOON

PHYSICS

TEST PAPER WITH SOLUTION

SECTION-A

1. A helicopter is flying horizontally with a speed 'v' at an altitude 'h' has to drop a food packet for a man on the ground. What is the distance of helicopter from the man when the food packet is dropped?

- (1) $\sqrt{\frac{2ghv^2 + 1}{h^2}}$ (2) $\sqrt{2ghv^2 + h^2}$
 (3) $\sqrt{\frac{2v^2h}{g} + h^2}$ (4) $\sqrt{\frac{2gh}{v^2} + h^2}$

Official Ans. by NTA (3)

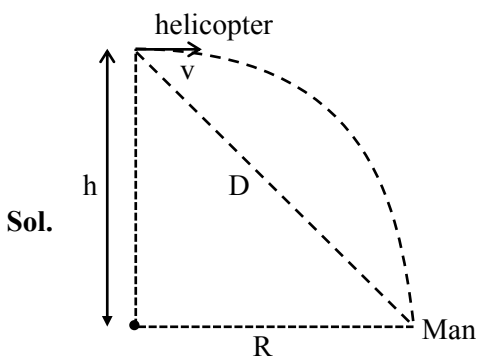

$$R = \sqrt{\frac{2h}{g}} \cdot v$$

$$D = \sqrt{R^2 + h^2} = \sqrt{\left(\sqrt{\frac{2h}{g}} \cdot v\right)^2 + h^2}$$

$$D = \sqrt{\frac{2hv^2}{g} + h^2}$$

Option (3) is correct

2. In the following logic circuit the sequence of the inputs A, B are (0, 0), (0,1), (1, 0) and (1, 1). The output Y for this sequence will be :

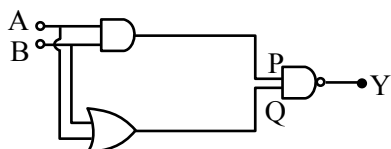

- (1) 1, 0, 1, 0 (2) 0, 1, 0, 1
 (3) 1, 1, 1, 0 (4) 0, 0, 1, 1

Official Ans. by NTA (3)

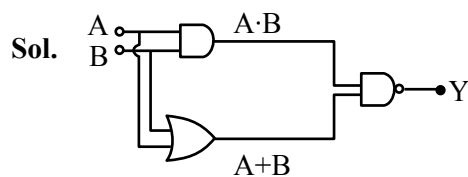

$$Y = \overline{(A \cdot B)} \cdot (A + B)$$

$$Y_{(0,0)} = 1$$

$$Y_{(0,1)} = 1$$

$$Y_{(1,0)} = 1$$

$$Y_{(1,1)} = 0$$

Option (3) is correct

3. Two particles A and B having charges $20 \mu\text{C}$ and $-5 \mu\text{C}$ respectively are held fixed with a separation of 5 cm. At what position a third charged particle should be placed so that it does not experience a net electric force?

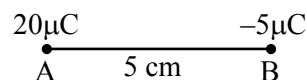

- (1) At 5 cm from $20 \mu\text{C}$ on the left side of system
 (2) At 5 cm from $-5 \mu\text{C}$ on the right side
 (3) At 1.25 cm from $-5 \mu\text{C}$ between two charges
 (4) At midpoint between two charges

Official Ans. by NTA (2)

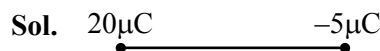

Null point is possible only right side of $-5 \mu\text{C}$

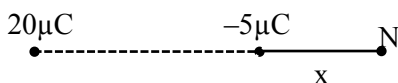

$$E_N = +\frac{k(-5\mu\text{C})}{x^2} + \frac{k(20\mu\text{C})}{(5+x)^2} = 0$$

$$x = 5 \text{ cm}$$

\therefore option (2) is correct

4. A reversible engine has an efficiency of $\frac{1}{4}$. If the temperature of the sink is reduced by 58°C , its efficiency becomes double. Calculate the temperature of the sink :

- (1) 174°C (2) 280°C
 (3) 180.4°C (4) 382°C

Official Ans. by NTA (1)

Official Ans. by ALLEN (Bonus)

Sol. $T_2 =$ sink temperature

$$\eta = 1 - \frac{T_2}{T_1}$$

$$\frac{1}{4} = 1 - \frac{T_2}{T_1}$$

$$\frac{T_2}{T_1} = \frac{3}{4} \dots (i)$$

$$\frac{1}{2} = 1 - \frac{T_2 - 58}{T_1}$$

$$\frac{T_2 - 58}{T_1} = \frac{1}{2}$$

$$\frac{3}{4} = \frac{58}{T_1} + \frac{1}{2}$$

$$\frac{1}{4} = \frac{58}{T_1} \Rightarrow T_1 = 232$$

$$T_2 = \frac{3}{4} \times 232$$

$$T_2 = 174 \text{ K}$$

5. An object is placed at the focus of concave lens having focal length f . What is the magnification and distance of the image from the optical centre of the lens?

- (1) 1, ∞ (2) Very high, ∞
 (3) $\frac{1}{2}, \frac{f}{2}$ (4) $\frac{1}{4}, \frac{f}{4}$

Official Ans. by NTA (3)

Sol.

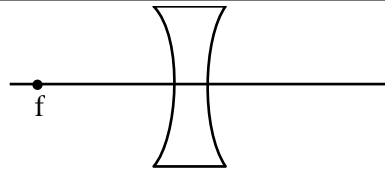

$$U = -f$$

$$\frac{1}{V} - \frac{1}{U} = \frac{1}{-f} \Rightarrow \frac{1}{V} = -\frac{2}{f}$$

$$V = \frac{-f}{2}$$

$$m = \frac{V}{U} = \frac{1}{2}$$

$$\text{distance} = \frac{f}{2}$$

Option (3)

6. A sample of a radioactive nucleus A disintegrates to another radioactive nucleus B, which in turn disintegrates to some other stable nucleus C. Plot of a graph showing the variation of number of atoms of nucleus B versus time is :

(Assume that at $t = 0$, there are no B atoms in the sample)

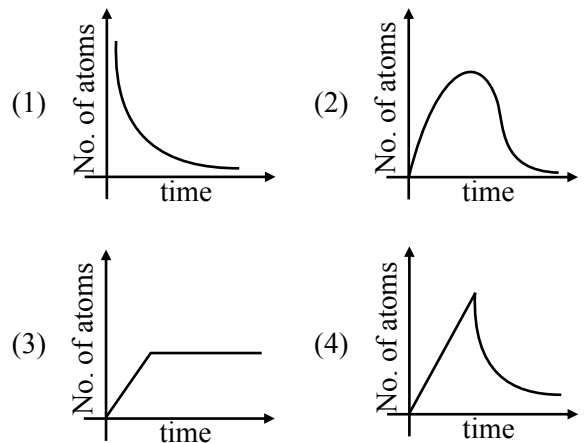

Official Ans. by NTA (2)

Sol. $A \longrightarrow B \longrightarrow C$ (stable)

Initially no. of atoms of B = 0 after $t = 0$, no. of atoms of B will start increasing & reaches maximum value when rate of decay of B = rate of formation of B.

After that maximum value, no. of atoms will start decreasing as growth & decay both are exponential functions, so best possible graph is (2)

Option (2)

7. A coil having N turns is wound tightly in the form of a spiral with inner and outer radii 'a' and 'b' respectively. Find the magnetic field at centre, when a current I passes through coil :

- (1) $\frac{\mu_0 IN}{2(b-a)} \log_e \left(\frac{b}{a} \right)$ (2) $\frac{\mu_0 I}{8} \left[\frac{a+b}{a-b} \right]$
 (3) $\frac{\mu_0 I}{4(a-b)} \left[\frac{1}{a} - \frac{1}{b} \right]$ (4) $\frac{\mu_0 I}{8} \left(\frac{a-b}{a+b} \right)$

Official Ans. by NTA (1)

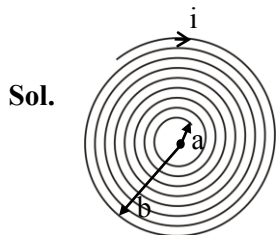

No. of turns in dx width = $\frac{N}{b-a} dx$

$$\int dB = \int_a^b \left(\frac{N}{b-a} \right) dx \frac{\mu_0 i}{2x}$$

$$B = \frac{N\mu_0 i}{2(b-a)} \ell n \left(\frac{b}{a} \right)$$

Option (1)

8. A body of mass M moving at speed V_0 collides elastically with a mass 'm' at rest. After the collision, the two masses move at angles θ_1 and θ_2 with respect to the initial direction of motion of the body of mass M. The largest possible value of the ratio M/m, for which the angles θ_1 and θ_2 will be equal, is :

- (1) 4 (2) 1 (3) 3 (4) 2

Official Ans. by NTA (3)

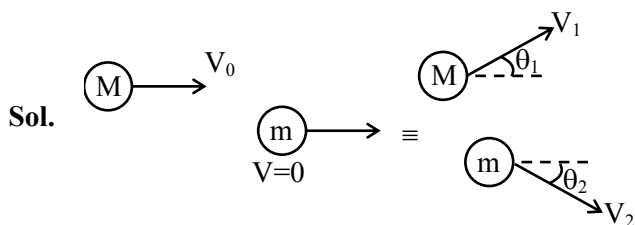

given $\theta_1 = \theta_2 = \theta$

from momentum conservation

in x-direction $MV_0 = MV_1 \cos \theta + mV_2 \cos \theta$

in y-direction $0 = MV_1 \sin \theta - mV_2 \sin \theta$

Solving above equations

$$V_2 = \frac{MV_1}{m}, V_0 = 2V_1 \cos \theta$$

From energy conservation

$$\frac{1}{2} MV_0^2 = \frac{1}{2} MV_1^2 + \frac{1}{2} mV_2^2$$

Substituting value of V_2 & V_0 , we will get

$$\frac{M}{m} + 1 = 4 \cos^2 \theta \leq 4$$

$$\frac{M}{m} \leq 3$$

Option (3)

9. The masses and radii of the earth and moon are (M_1, R_1) and (M_2, R_2) respectively. Their centres are at a distance 'r' apart. Find the minimum escape velocity for a particle of mass 'm' to be projected from the middle of these two masses:

(1) $V = \frac{1}{2} \sqrt{\frac{4G(M_1 + M_2)}{r}}$

(2) $V = \sqrt{\frac{4G(M_1 + M_2)}{r}}$

(3) $V = \frac{1}{2} \sqrt{\frac{2G(M_1 + M_2)}{r}}$

(4) $V = \frac{\sqrt{2G(M_1 + M_2)}}{r}$

Official Ans. by NTA (2)

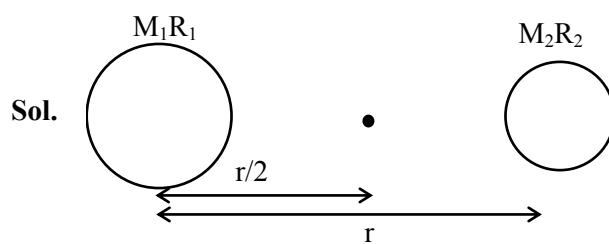

$$\frac{1}{2} mV^2 - \frac{GM_1 m}{r/2} - \frac{GM_2 m}{r/2} = 0$$

$$\frac{1}{2} mV^2 = \frac{2Gm}{r} (M_1 + M_2)$$

$$V = \sqrt{\frac{4G(M_1 + M_2)}{r}}$$

Option (2)

10. A small square loop of side 'a' and one turn is placed inside a larger square loop of side b and one turn ($b \gg a$). The two loops are coplanar with their centres coinciding. If a current I is passed in the square loop of side 'b', then the coefficient of mutual inductance between the two loops is :

- (1) $\frac{\mu_0}{4\pi} 8\sqrt{2} \frac{a^2}{b}$ (2) $\frac{\mu_0}{4\pi} \frac{8\sqrt{2}}{a}$
 (3) $\frac{\mu_0}{4\pi} 8\sqrt{2} \frac{b^2}{a}$ (4) $\frac{\mu_0}{4\pi} \frac{8\sqrt{2}}{b}$

Official Ans. by NTA (1)

Sol.

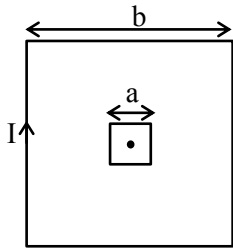

$$B = \left[\frac{\mu_0}{4\pi} \frac{I}{b/2} \times 2 \sin 45^\circ \right] \times 4$$

$$\phi = 2\sqrt{2} \frac{\mu_0}{\pi} \frac{I}{b} \times a^2$$

$$\therefore M = \frac{\phi}{I} = \frac{2\sqrt{2} \mu_0 a^2}{\pi b} = \frac{\mu_0}{4\pi} 8\sqrt{2} \frac{a^2}{b}$$

Option (1)

11. Choose the correct waveform that can represent the voltage across R of the following circuit, assuming the diode is ideal one:

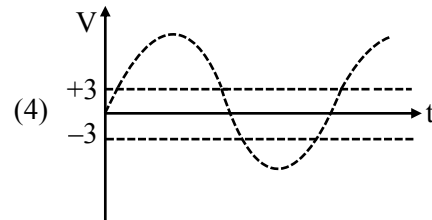
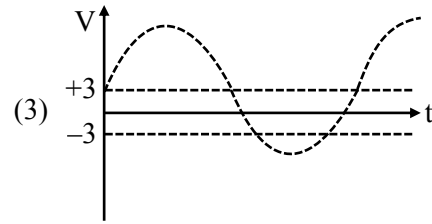
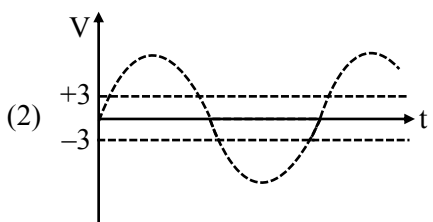
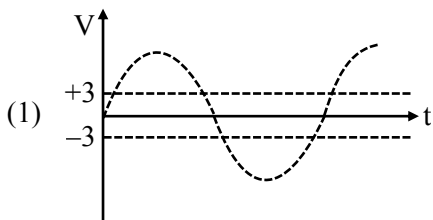
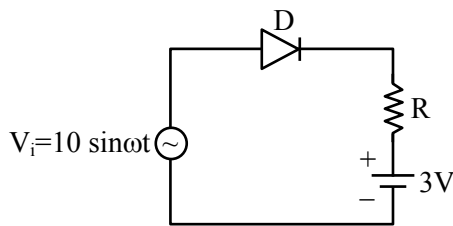

Official Ans. by NTA (3)

Official Ans. by ALLEN (1)

Sol. When $V_i > 3$ volt, $V_R > 0$

Because diode will be in forward biased state

When $V_i \leq 3$ volt ; $V_R = 0$

Because diode will be in reverse biased state.

12. A uniform heavy rod of weight 10 kg ms^{-2} , cross-sectional area 100 cm^2 and length 20 cm is hanging from a fixed support. Young modulus of the material of the rod is $2 \times 10^{11} \text{ Nm}^{-2}$. Neglecting the lateral contraction, find the elongation of rod due to its own weight.

- (1) $2 \times 10^{-9} \text{ m}$ (2) $5 \times 10^{-8} \text{ m}$
 (3) $4 \times 10^{-8} \text{ m}$ (4) $5 \times 10^{-10} \text{ m}$

Official Ans. by NTA (4)

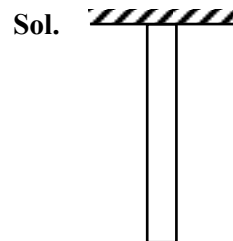

We know,

$$\Delta \ell = \frac{WL}{2AY}$$

$$\Delta \ell = \frac{10 \times 1}{2 \times 5} \times 100 \times 10^{-4} \times 2 \times 10^{11}$$

$$\Delta \ell = \frac{1}{2} \times 10^{-9} = 5 \times 10^{-10} \text{ m}$$

Option (4)

13. Two plane mirrors M_1 and M_2 are at right angle to each other shown. A point source 'P' is placed at 'a' and '2a' meter away from M_1 and M_2 respectively. The shortest distance between the images thus formed is : (Take $\sqrt{5} = 2.3$)

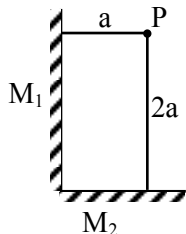

- (1) 3a (2) 4.6 a
 (3) 2.3 a (4) $2\sqrt{10} a$

Official Ans. by NTA (2)

Sol.

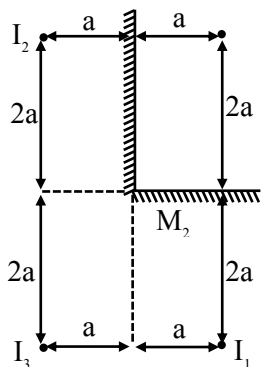

Shortest distance is 2a between I_1 & I_3

But answer given is for I_1 & I_2

$$\sqrt{(4a)^2 + (2a)^2}$$

$$a\sqrt{20}$$

$$4.47 a$$

Option (2)

14. Match List-I with List-II.

List-I	List-II
(a) Torque	(i) MLT^{-1}
(b) Impulse	(ii) MT^{-2}
(c) Tension	(iii) ML^2T^{-2}
(d) Surface Tension	(iv) MLT^{-2}

Choose the **most appropriate** answer from the option given below :

- (1) (a)–(iii), (b)–(i), (c)–(iv), (d)–(ii)
 (2) (a)–(ii), (b)–(i), (c)–(iv), (d)–(iii)
 (3) (a)–(i), (b)–(iii), (c)–(iv), (d)–(ii)
 (4) (a)–(iii), (b)–(iv), (c)–(i), (d)–(ii)

Official Ans. by NTA (1)

Sol. torque $\tau \rightarrow ML^2T^{-2}$ (III)

Impulse $I \Rightarrow MLT^{-1}$ (I)

Tension force $\Rightarrow MLT^{-2}$ (IV)

Surface tension $\Rightarrow MT^{-2}$ (II)

Option (1)

15. For an ideal gas the instantaneous change in pressure 'p' with volume 'v' is given by the equation $\frac{dp}{dv} = -ap$. If $p = p_0$ at $v = 0$ is the given

boundary condition, then the maximum temperature one mole of gas can attain is :

(Here R is the gas constant)

(1) $\frac{p_0}{aeR}$ (2) $\frac{ap_0}{eR}$

(3) infinity (4) $0^\circ C$

Official Ans. by NTA (1)

Sol. $\int_{p_0}^p \frac{dp}{p} = -a \int_0^v dv$

$$\ln\left(\frac{p}{p_0}\right) = -av$$

$$p = p_0 e^{-av}$$

For temperature maximum p-v product should be maximum

$$T = \frac{pv}{nR} = \frac{p_0 v e^{-av}}{R}$$

$$\frac{dT}{dv} = 0 \Rightarrow \frac{p_0}{R} \{e^{-av} + v e^{-av} (-a)\}$$

$$\frac{p_0 e^{-av}}{R} \{1 - av\} = 0$$

$$v = \frac{1}{a}, \infty$$

$$T = \frac{p_0 \cdot 1}{Rae} = \frac{p_0}{Rae}$$

at $v = \infty$

$$T = 0$$

Option (1)

16. Which of the following equations is dimensionally incorrect ?

Where t = time, h = height, s = surface tension, θ = angle, ρ = density, a , r = radius, g = acceleration due to gravity, v = volume, p = pressure, W = work done, Γ = torque, ϵ = permittivity, E = electric field, J = current density, L = length.

$$(1) v = \frac{\pi p a^4}{8 \eta L} \quad (2) h = \frac{2s \cos \theta}{\rho r g}$$

$$(3) J = \epsilon \frac{\partial E}{\partial t} \quad (4) W = \Gamma \theta$$

Official Ans. by NTA (1)

Sol. (i) $\frac{\pi p a^4}{8 \eta L} = \frac{dv}{dt}$ = Volumetric flow rate

(poiseuille's law)

$$(ii) h \rho g = \frac{2s}{r} \cos \theta$$

$$(iii) \text{RHS} \Rightarrow \epsilon \times \frac{1}{4\pi\epsilon_0} \frac{a}{r^2} \times \frac{1}{\epsilon} = \frac{q}{t} \times \frac{1}{r^2}$$

$$= \frac{I}{L^2} = \text{IL}^{-2}$$

LHS

$$T = \frac{I}{A} = \text{IL}^{-2}$$

$$(iv) W = \tau \theta$$

Option (1)

17. Angular momentum of a single particle moving with constant speed along circular path :

- (1) changes in magnitude but remains same in the direction
- (2) remains same in magnitude and direction
- (3) remains same in magnitude but changes in the direction
- (4) is zero

Official Ans. by NTA (2)

Sol.

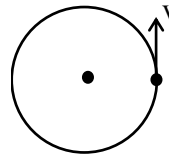

$$|\vec{L}| = mvr$$

And direction will be upward & remain constant
Option (2)

18. In an ac circuit, an inductor, a capacitor and a resistor are connected in series with $X_L = R = X_C$.

Impedance of this circuit is :

- (1) $2R^2$
- (2) Zero
- (3) R
- (4) $R\sqrt{2}$

Official Ans. by NTA (3)

Sol. $Z = \sqrt{(X_L - X_C)^2 + R^2} = R \because X_L = X_C$

Option (3)

19. A moving proton and electron have the same de-Broglie wavelength. If K and P denote the K.E. and momentum respectively. Then choose the correct option :

- (1) $K_p < K_e$ and $P_p = P_e$
- (2) $K_p = K_e$ and $P_p = P_e$
- (3) $K_p < K_e$ and $P_p < P_e$
- (4) $K_p > K_e$ and $P_p = P_e$

Official Ans. by NTA (1)

Sol. $\lambda_p = \frac{h}{P_p} \quad \lambda_e = \frac{h}{P_e}$

$$\because \lambda_p = \lambda_e$$

$$\Rightarrow P_p = P_e$$

$$(K)_p = \frac{P_p^2}{2m_p}$$

$$(K)_e = \frac{P_e^2}{2m_e}$$

$$K_p < K_e \text{ as } m_p > m_e$$

Option (1)

20. Consider a galvanometer shunted with 5Ω resistance and 2% of current passes through it.

What is the resistance of the given galvanometer ?

- (1) 300Ω (2) 344Ω
 (3) 245Ω (4) 226Ω

Official Ans. by NTA (3)

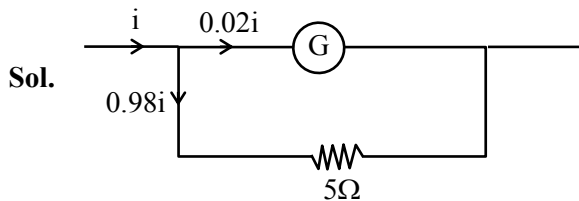

$$0.02i R_g = 0.98i \times 5$$

$$R_g = 245\Omega$$

Option (3)

SECTION-B

1. When a rubber ball is taken to a depth of _____ m in deep sea, its volume decreases by 0.5%.

(The bulk modulus of rubber = $9.8 \times 10^8 \text{ Nm}^{-2}$

Density of sea water = 10^3 kgm^{-3}

$$g = 9.8 \text{ m/s}^2$$

Official Ans. by NTA (500)

Sol.

$$B = -\frac{\Delta P}{\left(\frac{\Delta V}{V}\right)} = -\frac{\rho gh}{\left(\frac{\Delta V}{V}\right)}$$

$$-\frac{B \frac{\Delta V}{V}}{\rho g} = h$$

$$\frac{9.8 \times 10^8 \times 0.5}{100 \times 10^3 \times 9.8} = h$$

$$h = 500$$

2. A particle of mass 1 kg is hanging from a spring of force constant 100 Nm^{-1} . The mass is pulled slightly downward and released so that it executes free simple harmonic motion with time period T. The time when the kinetic energy and potential energy of the system will become equal, is $\frac{T}{x}$. The value of x is _____.

Official Ans. by NTA (8)

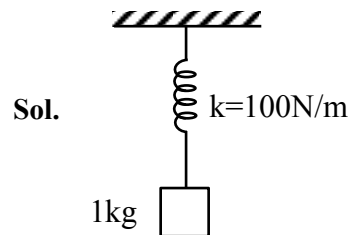

$$KE = PE$$

$$y = \frac{A}{\sqrt{2}} = A \sin \omega t$$

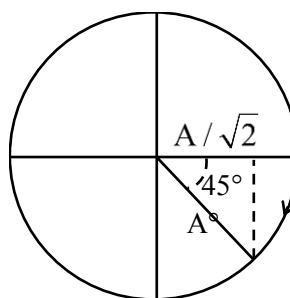

$$t = \frac{T}{8} = \frac{T}{x}$$

$$x = 8$$

3. If the sum of the heights of transmitting and receiving antennas in the line of sight of communication is fixed at 160 m, then the maximum range of LOS communication is _____ km.

(Take radius of Earth = 6400 km)

Official Ans. by NTA (64)

Sol. $h_T = h_R = 160 \dots (i)$

$$d = \sqrt{2Rh_T} + \sqrt{2Rh_R}$$

$$d = \sqrt{2R} \left[\sqrt{h_T} + \sqrt{h_R} \right]$$

$$d = \sqrt{2R} \left[\sqrt{x} + \sqrt{160-x} \right]$$

$$\frac{d(d)}{dx} = 0$$

$$\frac{1}{2\sqrt{x}} + \frac{1(-1)}{2\sqrt{160-x}} = 0$$

$$\frac{1}{\sqrt{x}} = \frac{1}{\sqrt{160-x}}$$

$$x = 80 \text{ m}$$

$$d_{\max} = \sqrt{2 \times 6400} \left[\sqrt{\frac{80}{1000}} + \sqrt{\frac{20}{1000}} \right]$$

$$= \frac{80\sqrt{2} \times 2\sqrt{80}}{10\sqrt{10}}$$

$$= 8 \times 2 \times \sqrt{2} \times 2\sqrt{2} = 64 \text{ km}$$

4. A square shaped wire with resistance of each side 3Ω is bent to form a complete circle. The resistance between two diametrically opposite points of the circle in unit of Ω will be _____.

Official Ans. by NTA (3)

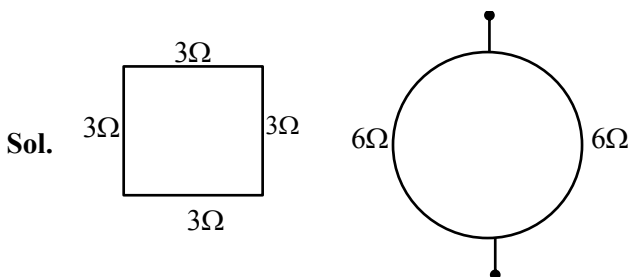

$$R_{\text{eq}} = 3\Omega$$

5. A wire having a linear mass density $9.0 \times 10^{-4} \text{ kg/m}$ is stretched between two rigid supports with a tension of 900 N . The wire resonates at a frequency of 500 Hz . The next higher frequency at which the same wire resonates is 550 Hz . The length of the wire is _____ m.

Official Ans. by NTA (10)

Sol. $\mu = 9.0 \times 10^{-4} \frac{\text{kg}}{\text{m}}$

$$T = 900 \text{ N}$$

$$V = \sqrt{\frac{T}{\mu}} = \sqrt{\frac{900}{9 \times 10^{-4}}} = 1000 \text{ m/s}$$

$$f_1 = 500 \text{ Hz}$$

$$f = 550$$

$$\frac{nV}{2\ell} = 500 \dots (i)$$

$$\frac{(n+1)V}{2\ell} = 500 \dots (ii)$$

$$(ii) - (i) \quad \frac{V}{2\ell} = 50$$

$$\ell = \frac{1000}{2 \times 50} = 10$$

6. The voltage drop across 15Ω resistance in the given figure will be _____ V.

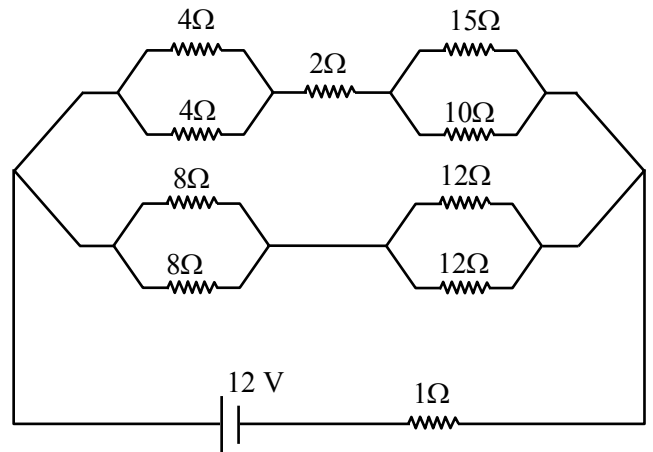

Official Ans. by NTA (6)

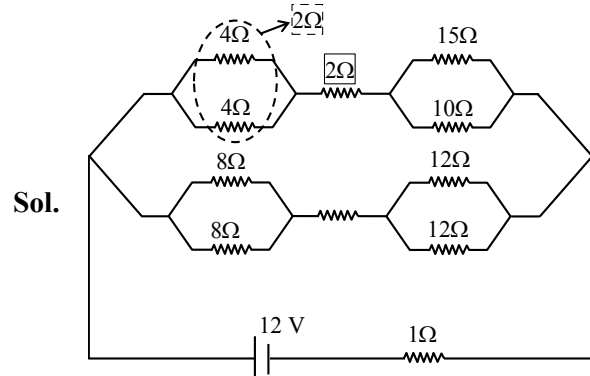

\Rightarrow effective circuit diagram will be

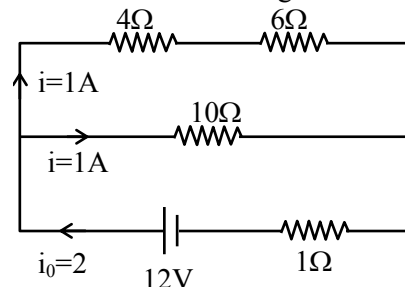

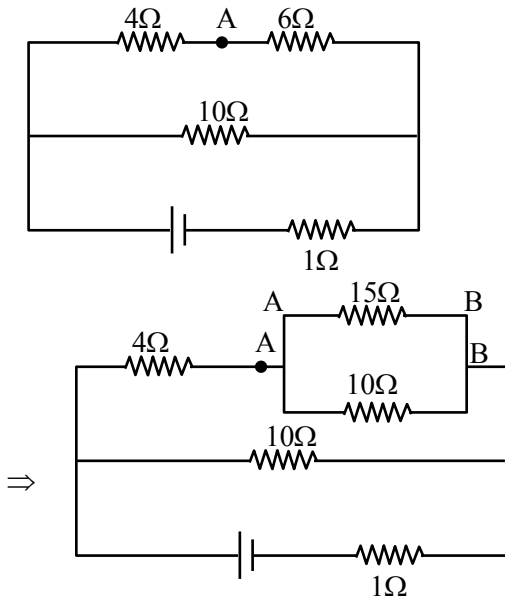

Point drop across $6\Omega = 1 \times 6 = 6 = V_{AB}$
 \Rightarrow Hence point drop across $15\Omega = 6 \text{ volt} = V_{AB}$

7. A block moving horizontally on a smooth surface with a speed of 40 ms^{-1} splits into two equal parts. If one of the parts moves at 60 ms^{-1} in the same direction, then the fractional change in the kinetic energy will be $x : 4$ where $x =$ _____.

Official Ans. by NTA (1)

Sol.

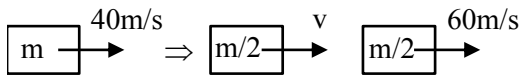

$$P_i = P_f$$

$$m \times 40 = \frac{m}{2} \times v + \frac{m}{2} \times 60$$

$$40 = \frac{v}{2} + 30$$

$$\Rightarrow v = 20$$

$$(K.E.)_i = \frac{1}{2} m \times (40)^2 = 800m$$

$$(K.E.)_f = \frac{1}{2} \frac{m}{2} \cdot (20)^2 + \frac{1}{2} \cdot \frac{m}{2} \cdot (60)^2 = 1000m$$

$$|\Delta K.E.| = |1000m - 800m| = 200m$$

$$\frac{\Delta K.E.}{(K.E.)_i} = \frac{200m}{800m} = \frac{1}{4} = \frac{x}{4}$$

$$x = 1$$

8. The electric field in an electromagnetic wave is given by $E = (50 \text{ NC}^{-1}) \sin \omega (t - x/c)$

The energy contained in a cylinder of volume V is $5.5 \times 10^{-12} \text{ J}$. The value of V is _____ cm^3 .

(given $\epsilon_0 = 8.8 \times 10^{-12} \text{ C}^2 \text{ N}^{-1} \text{ m}^{-2}$)

Official Ans. by NTA (500)

Sol. $E = 50 \sin \left(\omega t - \frac{\omega}{c} \cdot x \right)$

$$\text{Energy density} = \frac{1}{2} \epsilon_0 E_0^2$$

$$\text{Energy for volume } V = \frac{1}{2} \epsilon_0 E_0^2 \cdot V = 5.5 \times 10^{-12}$$

$$\frac{1}{2} 8.8 \times 10^{-12} \times 2500V = 5.5 \times 10^{-12}$$

$$V = \frac{5.5 \times 2}{2500 \times 8.8}$$

$$= .0005 \times 10^6 \text{ (c.m)}^3$$

$$= 500 \text{ (c.m)}^3$$

9. A capacitor of $50 \mu\text{F}$ is connected in a circuit as shown in figure. The charge on the upper plate of the capacitor is _____ μC .

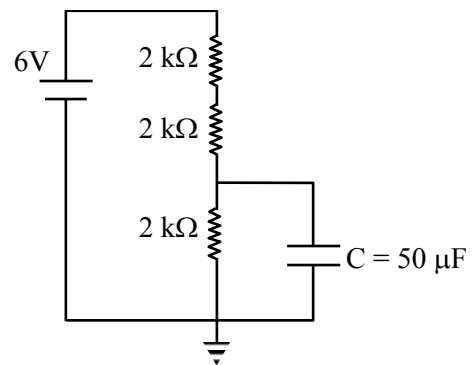

Official Ans. by NTA (100)

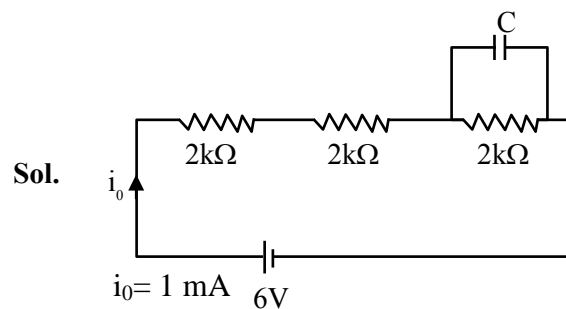

Pot. Diff. across each resistor = 2V

$$q = CV$$

$$= 50 \times 10^{-6} \times 2 = 100 \times 10^{-6} = 100 \mu\text{C}$$

10. A car is moving on a plane inclined at 30° to the horizontal with an acceleration of 10 ms^{-2} parallel to the plane upward. A bob is suspended by a string from the roof of the car. The angle in degrees which the string makes with the vertical is _____. (Take $g = 10 \text{ ms}^{-2}$)

Official Ans. by NTA (30)

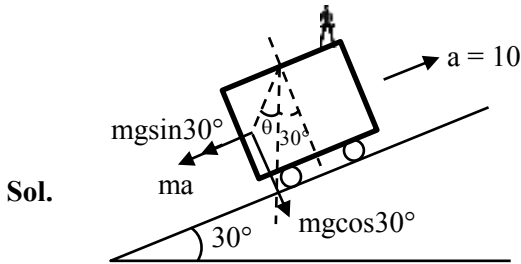

$$\tan(30 + \theta) = \frac{mg \sin 30^\circ + ma}{mg \cos 30^\circ}$$

$$\tan(30 + \theta) = \frac{5 + 10}{5\sqrt{3}} = \frac{1 + 2}{\sqrt{3}}$$

$$\frac{\tan \theta + \frac{1}{\sqrt{3}}}{1 - \frac{1}{\sqrt{3}} \tan \theta} = \sqrt{3}$$

$$\sqrt{3} \tan \theta + 1 = 3 - \sqrt{3} \tan \theta$$

$$2\sqrt{3} \tan \theta = 2$$

$$\tan \theta = \frac{1}{\sqrt{3}}$$

$$\theta = 30^\circ$$

FINAL JEE-MAIN EXAMINATION – AUGUST, 2021

(Held On Tuesday 31st August, 2021)

TIME : 9 : 00 AM to 12 : 00 NOON

CHEMISTRY

TEST PAPER WITH SOLUTION

SECTION-A

1. The **correct** order of reactivity of the given chlorides with acetate in acetic acid is :

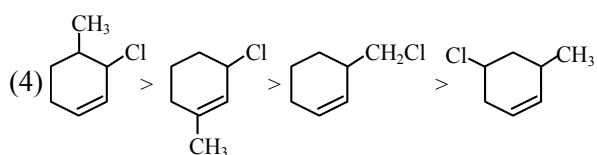
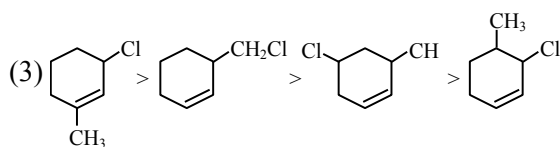
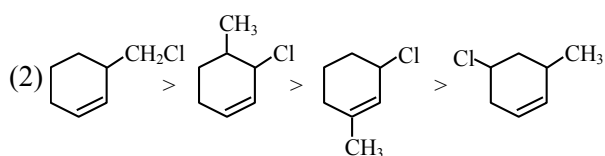
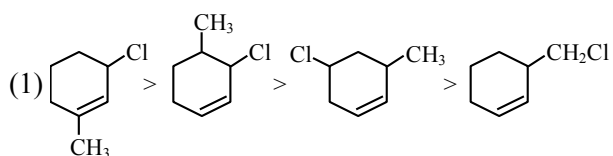

Official Ans. by NTA (1)

Sol. As it is example of SN^1 .

so carbocation stability \uparrow , reaction rate \uparrow

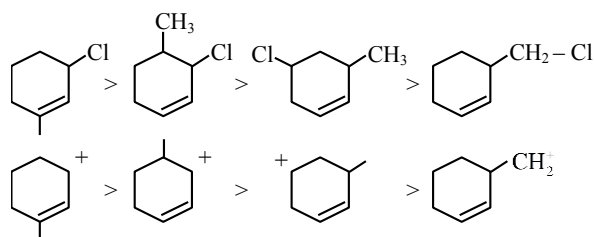

2. Select the graph that correctly describes the adsorption isotherms at two temperatures T_1 and T_2 ($T_1 > T_2$) for a gas :

(x – mass of the gas adsorbed ; m – mass of adsorbent ; P – pressure)

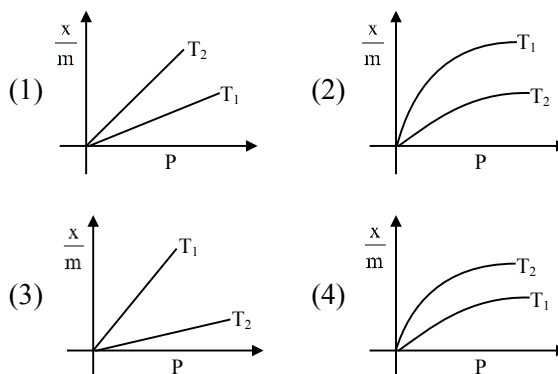

Official Ans. by NTA (4)

Sol. $\frac{x}{m} \propto P^{1/n} \left(0 < \frac{1}{n} < 1 \right)$

On Increasing temperature $\frac{x}{m}$ decreases.

\therefore adsorption is generally exothermic

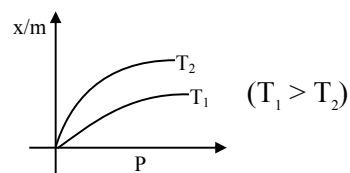

3. The major component/ingredient of Portland Cement is :

- (1) tricalcium aluminate
- (2) tricalcium silicate
- (3) dicalcium aluminate
- (4) dicalcium silicate

Official Ans. by NTA (2)

Sol. Major component of portland cement is "Tricalcium silicate (51% , $3CaO.SiO_2$)"

4. In the structure of the dichromate ion, there is a :
- (1) linear symmetrical Cr–O–Cr bond.
 - (2) non-linear symmetrical Cr–O–Cr bond.
 - (3) linear unsymmetrical Cr–O–Cr bond.
 - (4) non-linear unsymmetrical Cr–O–Cr bond.

Official Ans. by NTA (2)

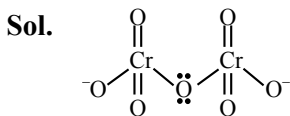

dichromate ion contain non-linear symmetrical Cr–O–Cr Bond

5. Which one of the following compounds contains β -C₁-C₄ glycosidic linkage ?
- (1) Lactose (2) Sucrose
(3) Maltose (4) Amylose

Official Ans. by NTA (1)

Sol. In Lactose it is β C₁ – C₄ glycosidic linkage.

In Maltose, Amylose α C₁ – C₄ glycosidic linkage is present

6. The major products A and B in the following set of reactions are :

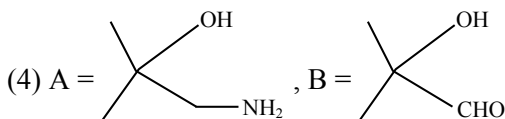
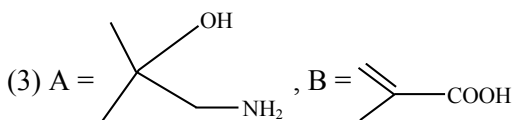
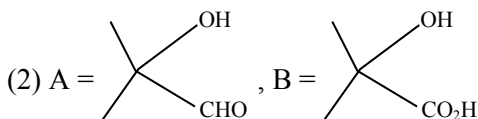
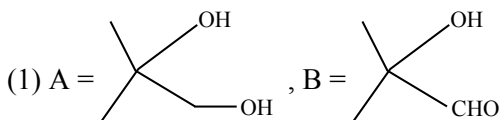
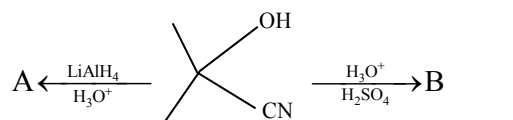

Official Ans. by NTA (3)

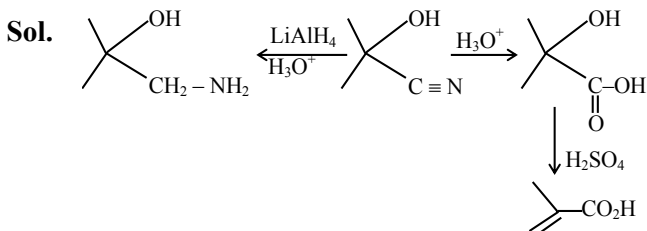

7. Which one of the following lanthanides exhibits +2 oxidation state with diamagnetic nature ?
(Given Z for Nd = 60, Yb = 70, La = 57, Ce = 58)
- (1) Nd (2) Yb (3) La (4) Ce

Official Ans. by NTA (2)

Sol. Ytterbium shows +2 oxidation state with diamagnetic nature

So ans is 2

8. Given below are two statements : one is labelled as **Assertion (A)** and the other is labelled as **Reason (R)**.

Assertion (A) : Aluminium is extracted from bauxite by the electrolysis of molten mixture of Al₂O₃ with cryolite.

Reason (R) : The oxidation state of Al in cryolite is +3.

In the light of the above statements, choose the **most appropriate** answer from the options given below :

- (1) **(A)** is true but **(R)** is false
(2) **(A)** is false but **(R)** is true.
(3) Both **(A)** and **(R)** are correct and **(R)** is the correct explanation of **(A)**
(4) Both **(A)** and **(R)** are correct but **(R)** is not the correct explanation of **(A)**

Official Ans. by NTA (4)

Sol. (A) Aluminium is reactive metal so Aluminium is extracted by electrolysis of Alumina with molten mixture of Cryolite

(B) Cryolite, Na₃AlF₆

Here Al is in +3 O.S.

So Answer is 4

9. The major product formed in the following reaction is :

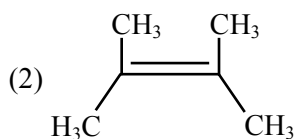
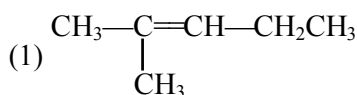
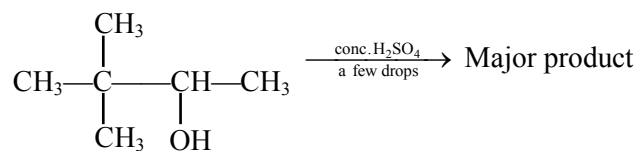

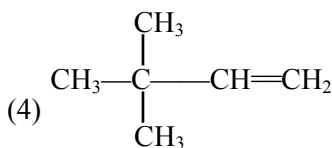
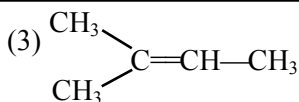

Official Ans. by NTA (2)

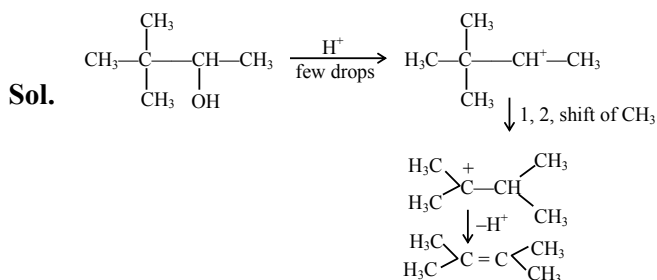

10. Monomer of Novolac is :
- (1) 3-Hydroxybutanoic acid
 - (2) phenol and melamine
 - (3) o-Hydroxymethylphenol
 - (4) 1,3-Butadiene and styrene

Official Ans. by NTA (3)

Sol. Monomer of Novolac is

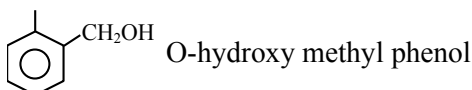

11. Given below are two statements :
- Statement-I** : The process of producing syn-gas is called gasification of coal.
- Statement-II** : The composition of syn-gas is $\text{CO} + \text{CO}_2 + \text{H}_2$ (1 : 1 : 1)
- In the light of the above statements, choose the **most appropriate** answer from the options given below :

- (1) **Statement-I** is false but **Statement-II** is true
- (2) **Statement-I** is true but **Statement-II** is false
- (3) Both **Statement-I** and **Statement-II** are false
- (4) Both **Statement-I** and **Statement-II** are true

Official Ans. by NTA (2)

Sol. The process of producing syn-gas from coal is called gasification of coal.

Syn-gas having composition of CO & H_2 in 1 : 1

12. Given below are two statements : one is labelled as **Assertion (A)** and the other is labelled as **Reason (R)**.
- Assertion (A)** : Treatment of bromine water with propene yields 1-bromopropan-2-ol.

Reason (R) : Attack of water on bromonium ion follows Markovnikov rule and results in 1-bromopropan-2-ol.

In the light of the above statements, choose the **most appropriate** answer from the options given below :

- (1) Both **(A)** and **(R)** are true but **(R)** is NOT the correct explanation of **(A)**
- (2) **(A)** is false but **(R)** is true.
- (3) Both **(A)** and **(R)** are true and **(R)** is the correct explanation of **(A)**
- (4) **(A)** is true but **(R)** is false

Official Ans. by NTA (3)

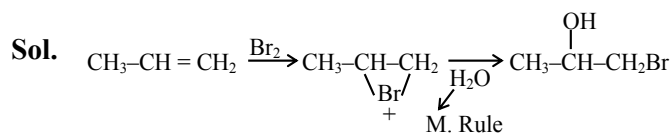

Its IUPAC name 1-bromopropan-2-ol

A and R are true and (R) is the correct explanation of (A)

13. The denticity of an organic ligand, biuret is :

- (1) 2
- (2) 4
- (3) 3
- (4) 6

Official Ans. by NTA (1)

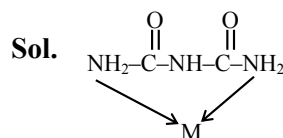

Biuret :- Bidentate ligand

The denticity of organic ligand is 2.

14. Given below are two statements : one is labelled as **Assertion (A)** and the other is labelled as **Reason (R)**.

Assertion (A) : Metallic character decreases and non-metallic character increases on moving from left to right in a period.

Reason (R) : It is due to increase in ionisation enthalpy and decrease in electron gain enthalpy, when one moves from left to right in a period.

In the light of the above statements, choose the **most appropriate** answer from the options given below :

- (1) (A) is false but (R) is true.
- (2) (A) is true but (R) is false
- (3) Both (A) and (R) are correct and (R) is the correct explanation of (A)
- (4) Both (A) and (R) are correct but (R) is not the correct explanation of (A)

Official Ans. by NTA (2)

Sol. From left to right in periodic table :-

Metallic character decreases

Non-metallic character increases

⇒ It is due to increase in ionization enthalpy and increase in electron gain enthalpy.

15. Choose the **correct** name for compound given below :

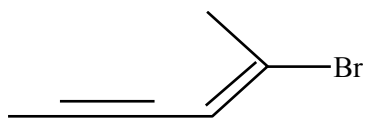

- (1) (4E)-5-Bromo-hex-4-en-2-yne
- (2) (2E)-2-Bromo-hex-4-yn-2-ene
- (3) (2E)-2-Bromo-hex-2-en-4-yne
- (4) (4E)-5-Bromo-hex-2-en-4-yne

Official Ans. by NTA (3)

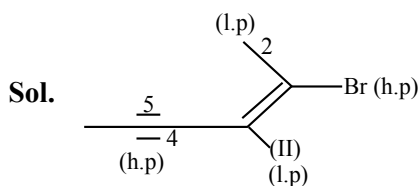

h.p. ⇒ higher priority
l.p. ⇒ lower priority

2E -2- bromo hex -2- en-4-yne

16. Which one of the following is the correct PV vs P plot at constant temperature for an ideal gas ? (P and V stand for pressure and volume of the gas respectively)

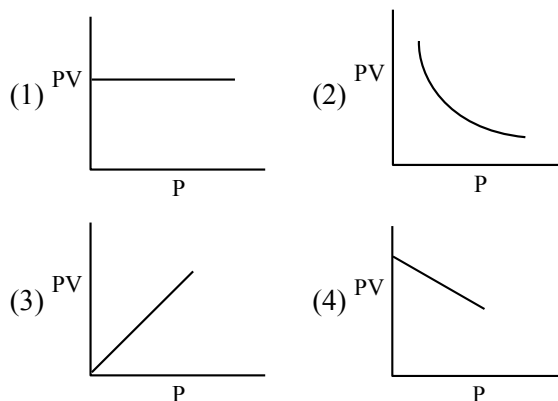

Official Ans. by NTA (1)

Sol. $PV = nRT$ (n,T constant)

$PV = \text{constant}$

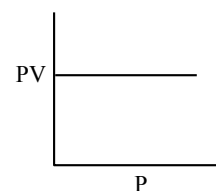

17. Given below are two statements : one is labelled as **Assertion (A)** and the other is labelled as **Reason (R) :**

Assertion (A) : A simple distillation can be used to separate a mixture of propanol and propanone.

Reason (R) : Two liquids with a difference of more than 20°C in their boiling points can be separated by simple distillations.

In the light of the above statements, choose the **most appropriate** answer from the options given below :

- (1) (A) is false but (R) is true.
- (2) Both (A) and (R) are correct but (R) is not the correct explanation of (A)
- (3) (A) is true but (R) is false
- (4) Both (A) and (R) are correct and (R) is the correct explanation of (A)

Official Ans. by NTA (4)

Sol. Both assertion & reason are correct & (R) is the correct explanation of (A)

18. Which one of the following 0.10 M aqueous solutions will exhibit the largest freezing point depression ?

- (1) hydrazine (2) glucose
(3) glycine (4) KHSO_4

Official Ans. by NTA (4)

18. \therefore Van't Hoff factor is highest for KHSO_4

\therefore colligative property (ΔT_f) will be highest for KHSO_4

19. BOD values (in ppm) for clean water (A) and polluted water (B) are expected respectively :

- (1) $A > 50, B < 27$ (2) $A > 25, B < 17$
(3) $A < 5, B > 17$ (4) $A > 15, B > 47$

Official Ans. by NTA (3)

Sol. BOD values of clean water (A) is less than 5 ppm

So $A < 5$

BOD values of polluted water (B) is greater than 17 ppm

So $B > 17$

So Ans. is 3

20. The structure of product C, formed by the following sequence of reactions is :

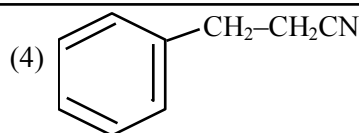
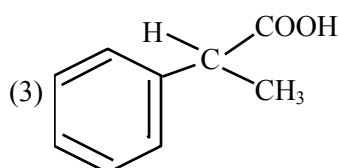
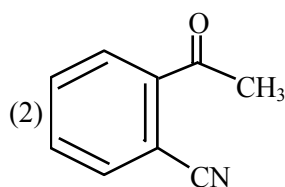
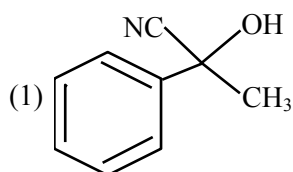
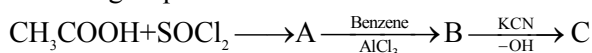

Official Ans. by NTA (1)

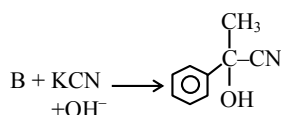
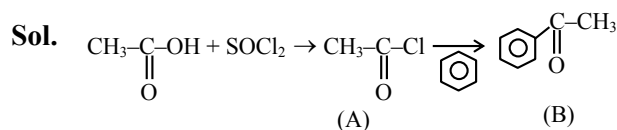

SECTION-B

1. Consider the following cell reaction :

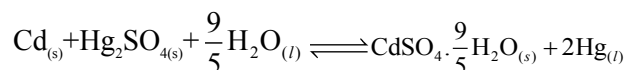

The value of E_{cell}^0 is 4.315 V at 25°C . If $\Delta H^\circ = -825.2 \text{ kJ mol}^{-1}$, the standard entropy change ΔS° in J K^{-1} is _____. (Nearest integer)
[Given : Faraday constant = 96487 C mol^{-1}]

Official Ans. by NTA (25)

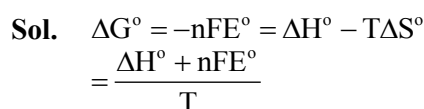

$$= \frac{(-825.2 \times 10^3) + (2 \times 96487 \times 4.315)}{298}$$

$$= \frac{-825.2 \times 10^3 + 832.682 \times 10^3}{298}$$

$$= \frac{7.483 \times 10^3}{298} = 25.11 \text{ JK}^{-1}\text{mol}^{-1}$$

\therefore Nearest integer answer is 25

2. The molarity of the solution prepared by dissolving 6.3 g of oxalic acid ($\text{H}_2\text{C}_2\text{O}_4 \cdot 2\text{H}_2\text{O}$) in 250 mL of water in mol L^{-1} is $x \times 10^{-2}$. The value of x is _____ (Nearest integer)

[Atomic mass : H : 1.0, C : 12.0, O : 16.0]

Official Ans. by NTA (20)

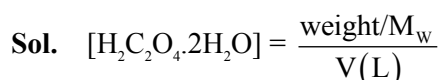

$$\Rightarrow x \times 10^{-2} = \frac{6.3 / 126}{250 / 1000}$$

$x = 20$

3. Consider the sulphides HgS, PbS, CuS, Sb₂S₃, As₂S₃ and CdS. Number of these sulphides soluble in 50% HNO₃ is _____.

Official Ans. by NTA (4)

Sol. Pbs, CuS, As₂S₃, CdS are soluble in 50% HNO₃
HgS, Sb₂S₃ are insoluble in 50% HNO₃

So Answer is 4.

4. The total number of reagents from those given below, that can convert nitrobenzene into aniline is _____. (Integer answer)

- I. Sn – HCl
- II. Sn – NH₄OH
- III. Fe – HCl
- IV. Zn – HCl
- V. H₂ – Pd
- VI. H₂ – Raney Nickel

Official Ans. by NTA (5)

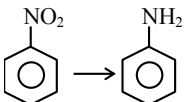
Sol.  Reagents used can be

- (i) Sn + HCl
 - (ii) Fe + HCl
 - (iii) Zn + HCl
 - (iv) H₂ – Pd
 - (v) H₂ (Raney Ni)
5. The number of halogen/(s) forming halic (V) acid is _____.

Official Ans. by NTA (3)

Sol. The number of halogen forming halic (V) acid

- HClO₃
- HBrO₃
- HIO₃

So Answer is 3

6. For a first order reaction, the ratio of the time for 75% completion of a reaction to the time for 50% completion is _____. (Integer answer)

Official Ans. by NTA (2)

Sol. $k = \frac{2.303}{t} \log \frac{a}{a-x}$

$$\frac{2.303}{t_{50\%}} \log \frac{100}{100-50} = \frac{2.303}{t_{75\%}} \log \frac{100}{100-75}$$

$$t_{75\%} = 2 t_{50\%}$$

7. The number of hydrogen bonded water molecule(s) associated with stoichiometry CuSO₄·5H₂O is _____.

Official Ans. by NTA (1)

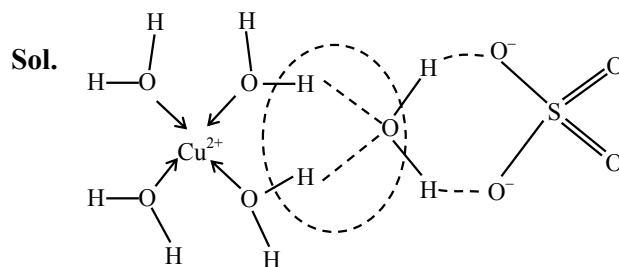

One hydrogen bonded H₂O molecule

8. According to the following figure, the magnitude of the enthalpy change of the reaction A + B → M + N in kJ mol⁻¹ is equal to _____. (Integer answer)

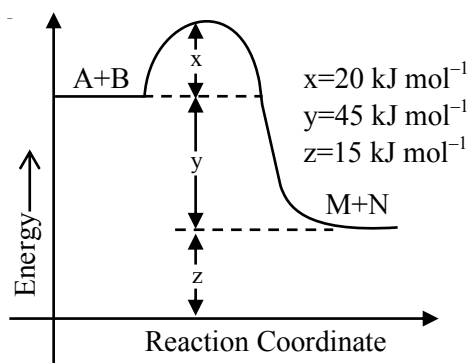

Official Ans. by NTA (45)

Sol.

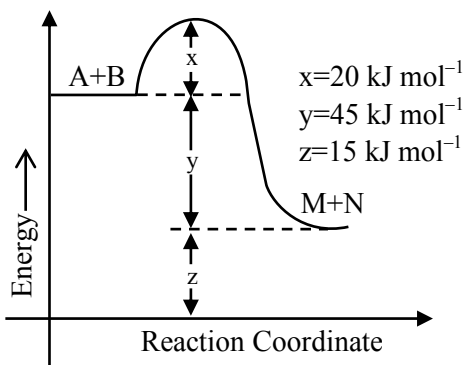

$$\Delta H = E_{ar} - E_{ab}$$

$$= 20 - 65$$

$$= -45 \text{ KJ/mol}$$

$$|\Delta H| = 45 \text{ KJ/mol}$$

9. Ge(Z = 32) in its ground state electronic configuration has x completely filled orbitals with $m_l = 0$. The value of x is _____.

Official Ans. by NTA (7)

Sol.

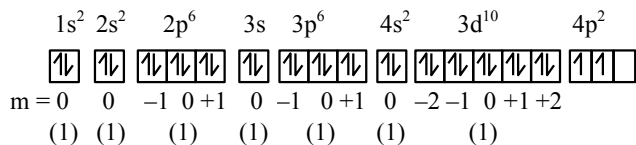

Completely filled orbital with $m_l = 0$ are

$$= 1+1+1+1+1+1+1$$

$$= 7$$

So Answer is 7

10. A_3B_2 is a sparingly soluble salt of molar mass M (g mol^{-1}) and solubility x g L^{-1} . The solubility product satisfies $K_{sp} = a \left(\frac{x}{M} \right)^5$. The value of a is

_____ (Integer answer)

Official Ans. by NTA (108)

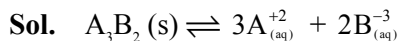

$$K_{sp} = (3s)^3 (2s)^2$$

$$K_{sp} = 108 S^5 \text{ \& } s = (X/M)$$

$$K_{sp} = 108 \left(\frac{x}{m} \right)^5$$

$$\text{given } K_{sp} = a \left(\frac{x}{m} \right)^5$$

$$\text{comparing } a = 108$$

FINAL JEE-MAIN EXAMINATION – AUGUST, 2021

(Held On Tuesday 31st August, 2021)

TIME : 9 : 00 AM to 12 : 00 NOON

MATHEMATICS

TEST PAPER WITH SOLUTION

SECTION-A

1. Let $*, \square \in \{\wedge, \vee\}$ be such that the Boolean expression $(p * \sim q) \Rightarrow (p \square q)$ is a tautology. Then :

(1) $* = \vee, \square = \vee$ (2) $* = \wedge, \square = \wedge$

(3) $* = \wedge, \square = \vee$ (4) $* = \vee, \square = \wedge$

Official Ans. by NTA (3)

Sol. $(p \wedge \sim q) \rightarrow (p \vee q)$ is tautology

p	q	$\sim q$	$p \wedge \sim q$	$p \vee q$	$(p \wedge \sim q) \rightarrow (p \vee q)$
T	T	F	F	T	T
T	F	T	T	T	T
F	T	F	F	T	T
F	F	T	F	F	T

2. The number of real roots of the equation

$e^{4x} + 2e^{3x} - e^x - 6 = 0$ is :

(1) 2 (2) 4

(3) 1 (4) 0

Official Ans. by NTA (3)

Sol. Let $e^x = t > 0$

$f(t) = t^4 + 2t^3 - t - 6 = 0$

$f'(t) = 4t^3 + 6t^2 - 1$

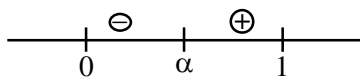

$f''(t) = 12t^2 + 12t > 0$

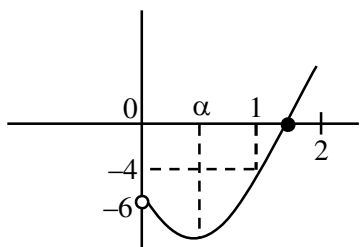

$f(0) = -6, f(1) = -4, f(2) = 24$

\Rightarrow Number of real roots = 1

3. The sum of 10 terms of the series

$\frac{3}{1^2 \times 2^2} + \frac{5}{2^2 \times 3^2} + \frac{7}{3^2 \times 4^2} + \dots$ is :

(1) 1 (2) $\frac{120}{121}$

(3) $\frac{99}{100}$ (4) $\frac{143}{144}$

Official Ans. by NTA (2)

Sol. $S = \frac{2^2 - 1^2}{1^2 \times 2^2} + \frac{3^2 - 2^2}{2^2 \times 3^2} + \frac{4^2 - 3^2}{3^2 \times 4^2} + \dots$

$= \left[\frac{1}{1^2} - \frac{1}{2^2} \right] + \left[\frac{1}{2^2} - \frac{1}{3^2} \right] + \left[\frac{1}{3^2} - \frac{1}{4^2} \right] + \dots + \left[\frac{1}{10^2} - \frac{1}{11^2} \right]$

$= 1 - \frac{1}{121}$

$= \frac{120}{121}$

4. Let the equation of the plane, that passes through the point (1, 4, -3) and contains the line of intersection of the planes $3x - 2y + 4z - 7 = 0$ and $x + 5y - 2z + 9 = 0$, be $\alpha x + \beta y + \gamma z + 3 = 0$, then $\alpha + \beta + \gamma$ is equal to :

(1) -23 (2) -15

(3) 23 (4) 15

Official Ans. by NTA (1)

Sol. Equation of plane is

$3x - 2y + 4z - 7 + \lambda(x + 5y - 2z + 9) = 0$

$(3 + \lambda)x + (5\lambda - 2)y + (4 - 2\lambda)z + 9\lambda - 7 = 0$

passing through (1, 4, -3)

$\Rightarrow 3 + \lambda + 20\lambda - 8 - 12 + 6\lambda + 9\lambda - 7 = 0$

$\Rightarrow \lambda = \frac{2}{3}$

\Rightarrow equation of plane is

$-11x - 4y - 8z + 3 = 0$

$\Rightarrow \alpha + \beta + \gamma = -23$

5. Let f be a non-negative function in $[0, 1]$ and twice differentiable in $(0, 1)$. If $\int_0^x \sqrt{1-(f'(t))^2} dt = \int_0^x f(t) dt$,

$0 \leq x \leq 1$ and $f(0) = 0$, then $\lim_{x \rightarrow 0} \frac{1}{x^2} \int_0^x f(t) dt :$

- (1) equals 0 (2) equals 1
 (3) does not exist (4) equals $\frac{1}{2}$

Official Ans. by NTA (4)

Sol. $\int_0^x \sqrt{1-(f'(t))^2} dt = \int_0^x f(t) dt \quad 0 \leq x \leq 1$

differentiating both the sides

$$\sqrt{1-(f'(x))^2} = f(x)$$

$$\Rightarrow 1 - (f'(x))^2 = f^2(x)$$

$$\frac{f'(x)}{\sqrt{1-f^2(x)}} = 1$$

$$\sin^{-1} f(x) = x + C$$

$$\because f(0) = 0 \Rightarrow C = 0 \Rightarrow f(x) = \sin x$$

Now $\lim_{x \rightarrow 0} \frac{\int_0^x \sin t dt}{x^2} \left(\frac{0}{0} \right) = \frac{1}{2}$

6. Let \vec{a} and \vec{b} be two vectors such that $|2\vec{a} + 3\vec{b}| = |3\vec{a} + \vec{b}|$ and the angle between \vec{a} and \vec{b}

is 60° . If $\frac{1}{8}\vec{a}$ is a unit vector, then $|\vec{b}|$ is equal to :

- (1) 4 (2) 6
 (3) 5 (4) 8

Official Ans. by NTA (3)

Sol. $|3\vec{a} + \vec{b}|^2 = |2\vec{a} + 3\vec{b}|^2$

$$(3\vec{a} + \vec{b}) \cdot (3\vec{a} + \vec{b}) = (2\vec{a} + 3\vec{b}) \cdot (2\vec{a} + 3\vec{b})$$

$$9\vec{a} \cdot \vec{a} + 6\vec{a} \cdot \vec{b} + \vec{b} \cdot \vec{b} = 4\vec{a} \cdot \vec{a} + 12\vec{a} \cdot \vec{b} + 9\vec{b} \cdot \vec{b}$$

$$5|\vec{a}|^2 - 6\vec{a} \cdot \vec{b} = 8|\vec{b}|^2$$

$$5(8)^2 - 6 \cdot 8 \cdot |\vec{b}| \cos 60^\circ = 8|\vec{b}|^2 \quad \left(\begin{array}{l} \because \frac{1}{8}|\vec{a}| = 1 \\ \Rightarrow |\vec{a}| = 8 \end{array} \right)$$

$$40 - 3|\vec{b}| = |\vec{b}|^2$$

$$\Rightarrow |\vec{b}|^2 + 3|\vec{b}| - 40 = 0$$

$$|\vec{b}| = -8, \quad |\vec{b}| = 5$$

(rejected)

7. The function $f(x) = |x^2 - 2x - 3| \cdot e^{9x^2 - 12x + 4}$ is not differentiable at exactly :

- (1) four points (2) three points
 (3) two points (4) one point

Official Ans. by NTA (3)

Sol. $f(x) = |(x-3)(x+1)| \cdot e^{(3x-2)^2}$

$$f(x) = \begin{cases} (x-3)(x+1) \cdot e^{(3x-2)^2} & ; x \in (3, \infty) \\ -(x-3)(x+1) \cdot e^{(3x-2)^2} & ; x \in [-1, 3] \\ (x-3) \cdot (x+1) \cdot e^{(3x-2)^2} & ; x \in (-\infty, -1) \end{cases}$$

Clearly, non-differentiable at $x = -1$ & $x = 3$.

8. Three numbers are in an increasing geometric progression with common ratio r . If the middle number is doubled, then the new numbers are in an arithmetic progression with common difference d . If the fourth term of GP is $3r^2$, then $r^2 - d$ is equal to :

- (1) $7 - 7\sqrt{3}$ (2) $7 + \sqrt{3}$
 (3) $7 - \sqrt{3}$ (4) $7 + 3\sqrt{3}$

Official Ans. by NTA (2)

Sol. Let numbers be $\frac{a}{r}, a, ar \rightarrow$ G.P

$$\frac{a}{r}, 2a, ar \rightarrow$$
 A.P $\Rightarrow 4a = \frac{a}{r} + ar \Rightarrow r + \frac{1}{r} = 4$

$$r = 2 \pm \sqrt{3}$$

$$4^{\text{th}} \text{ form of G.P} = 3r^2 \Rightarrow ar^2 = 3r^2 \Rightarrow a = 3$$

$$r = 2 + \sqrt{3}, a = 3, d = 2a - \frac{a}{r} = 3\sqrt{3}$$

$$r^2 - d = (2 + \sqrt{3})^2 - 3\sqrt{3}$$

$$= 7 + 4\sqrt{3} - 3\sqrt{3}$$

$$= 7 + \sqrt{3}$$

9. Which of the following is **not** correct for relation R on the set of real numbers ?

- (1) $(x, y) \in R \Leftrightarrow 0 < |x| - |y| \leq 1$ is neither transitive nor symmetric.
 (2) $(x, y) \in R \Leftrightarrow 0 < |x - y| \leq 1$ is symmetric and transitive.
 (3) $(x, y) \in R \Leftrightarrow |x| - |y| \leq 1$ is reflexive but not symmetric.
 (4) $(x, y) \in R \Leftrightarrow |x - y| \leq 1$ is reflexive and symmetric.

Official Ans. by NTA (2)

Sol. Note that (1,2) and (2,3) satisfy $0 < |x - y| \leq 1$ but (1,3) does not satisfy it so $0 \leq |x - y| \leq 1$ is symmetric but not transitive. So, (2) is correct.

10. The integral $\int \frac{1}{\sqrt[4]{(x-1)^3(x+2)^5}} dx$ is equal to :

(where C is a constant of integration)

- (1) $\frac{3}{4} \left(\frac{x+2}{x-1} \right)^{\frac{1}{4}} + C$ (2) $\frac{3}{4} \left(\frac{x+2}{x-1} \right)^{\frac{5}{4}} + C$
 (3) $\frac{4}{3} \left(\frac{x-1}{x+2} \right)^{\frac{1}{4}} + C$ (4) $\frac{4}{3} \left(\frac{x-1}{x+2} \right)^{\frac{5}{4}} + C$

Official Ans. by NTA (3)

Sol.
$$\int \frac{dx}{(x-1)^{3/4} (x+2)^{5/4}}$$

$$= \int \frac{dx}{\left(\frac{x+2}{x-1} \right)^{5/4} \cdot (x-1)^2}$$
 put $\frac{x+2}{x-1} = t$

$$= -\frac{1}{3} \int \frac{dt}{t^{5/4}}$$

$$= \frac{4}{3} \cdot \frac{1}{t^{1/4}} + C$$

$$= \frac{4}{3} \left(\frac{x-1}{x+2} \right)^{1/4} + C$$

11. If p and q are the lengths of the perpendiculars from the origin on the lines,

$$x \operatorname{cosec} \alpha - y \sec \alpha = k \cot 2\alpha \text{ and}$$

$$x \sin \alpha + y \cos \alpha = k \sin 2\alpha$$

respectively, then k^2 is equal to :

- (1) $4p^2 + q^2$ (2) $2p^2 + q^2$
 (3) $p^2 + 2q^2$ (4) $p^2 + 4q^2$

Official Ans. by NTA (1)

Sol. First line is $\frac{x}{\sin \alpha} - \frac{y}{\cos \alpha} = \frac{k \cos 2\alpha}{\sin 2\alpha}$

$$\Rightarrow x \cos \alpha - y \sin \alpha = \frac{k}{2} \cos 2\alpha$$

$$\Rightarrow p = \left| \frac{k}{2} \cos \alpha \right| \Rightarrow 2p = |k \cos 2\alpha| \dots (i)$$

second line is $x \sin \alpha + y \cos \alpha = k \sin 2\alpha$

$$\Rightarrow q = |k \sin 2\alpha| \dots (ii)$$

Hence $4p^2 + q^2 = k^2$ (From (i) & (ii))

12. $\operatorname{cosec} 18^\circ$ is a root of the equation :

- (1) $x^2 + 2x - 4 = 0$ (2) $4x^2 + 2x - 1 = 0$
 (3) $x^2 - 2x + 4 = 0$ (4) $x^2 - 2x - 4 = 0$

Official Ans. by NTA (4)

Sol. $\operatorname{cosec} 18^\circ = \frac{1}{\sin 18^\circ} = \frac{4}{\sqrt{5}-1} = \sqrt{5} + 1$

Let $\operatorname{cosec} 18^\circ = x = \sqrt{5} + 1$

$$\Rightarrow x - 1 = \sqrt{5}$$

Squaring both sides, we get

$$x^2 - 2x + 1 = 5$$

$$\Rightarrow x^2 - 2x - 4 = 0$$

13. If the following system of linear equations

$$2x + y + z = 5$$

$$x - y + z = 3$$

$$x + y + az = b$$

has no solution, then :

- (1) $a = -\frac{1}{3}, b \neq \frac{7}{3}$ (2) $a \neq \frac{1}{3}, b = \frac{7}{3}$
 (3) $a \neq -\frac{1}{3}, b = \frac{7}{3}$ (4) $a = \frac{1}{3}, b \neq \frac{7}{3}$

Official Ans. by NTA (4)

Sol. Here $D = \begin{vmatrix} 2 & 1 & 1 \\ 1 & -1 & 1 \\ 1 & 1 & a \end{vmatrix} = 2(-a-1) - 1(a-1) + 1+1 = 1-3a$

$D_3 = \begin{vmatrix} 2 & 1 & 5 \\ 1 & -1 & 3 \\ 1 & 1 & b \end{vmatrix} = 2(-b-3) - 1(b-3) + 5(1+1) = 7-3b$

for $a = \frac{1}{3}$, $b \neq \frac{7}{3}$, system has no solutions

14. The length of the latus rectum of a parabola, whose vertex and focus are on the positive x-axis at a distance R and S (>R) respectively from the origin, is :

- (1) $4(S+R)$ (2) $2(S-R)$
 (3) $4(S-R)$ (4) $2(S+R)$

Official Ans. by NTA (3)

Sol.

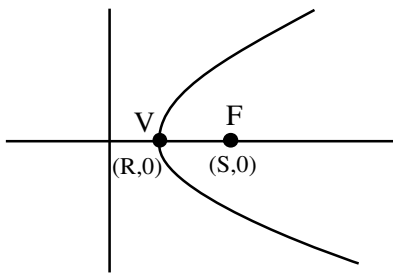

V → Vertex

F → focus

VF = S - R

So latus rectum = $4(S-R)$

15. If the function $f(x) = \begin{cases} \frac{1}{x} \log_e \left(\frac{1+\frac{x}{a}}{1-\frac{x}{b}} \right) & , x < 0 \\ k & , x = 0 \\ \frac{\cos^2 x - \sin^2 x - 1}{\sqrt{x^2 + 1} - 1} & , x > 0 \end{cases}$

is continuous at $x = 0$, then $\frac{1}{a} + \frac{1}{b} + \frac{4}{k}$ is equal to :

- (1) -5 (2) 5
 (3) -4 (4) 4

Official Ans. by NTA (1)

Sol. If $f(x)$ is continuous at $x = 0$, $RHL = LHL = f(0)$

$\lim_{x \rightarrow 0^+} f(x) = \lim_{x \rightarrow 0^+} \frac{\cos^2 x - \sin^2 x - 1}{\sqrt{x^2 + 1} - 1} \cdot \frac{\sqrt{x^2 + 1} + 1}{\sqrt{x^2 + 1} + 1}$ (Rationalisation)

$\lim_{x \rightarrow 0^+} -\frac{2 \sin^2 x}{x^2} \cdot (\sqrt{x^2 + 1} + 1) = -4$

$\lim_{x \rightarrow 0^-} f(x) = \lim_{x \rightarrow 0^-} \frac{1}{x} \ln \left(\frac{1+\frac{x}{a}}{1-\frac{x}{b}} \right)$

$\lim_{x \rightarrow 0^-} \frac{\ln \left(1+\frac{x}{a} \right)}{\left(\frac{x}{a} \right) \cdot a} + \frac{\ln \left(1-\frac{x}{b} \right)}{\left(-\frac{x}{b} \right) \cdot b}$

$= \frac{1}{a} + \frac{1}{b}$

So $\frac{1}{a} + \frac{1}{b} = -4 = k$

$\Rightarrow \frac{1}{a} + \frac{1}{b} + \frac{4}{k} = -4 - 1 = -5$

16. If $\frac{dy}{dx} = \frac{2^{x+y} - 2^x}{2^y}$, $y(0) = 1$, then $y(1)$ is equal to :

- (1) $\log_2(2+e)$ (2) $\log_2(1+e)$
 (3) $\log_2(2e)$ (4) $\log_2(1+e^2)$

Official Ans. by NTA (2)

Sol. $\frac{dy}{dx} = \frac{2^x 2^y - 2^x}{2^y}$

$2^y \frac{dy}{dx} = 2^x (2^y - 1)$

$\int \frac{2^y}{2^y - 1} dy = \int 2^x dx$

$\frac{\ln(2^y - 1)}{\ln 2} = \frac{2^x}{\ln 2} + C$

$\Rightarrow \log_2(2^y - 1) = 2^x \log_2 e + C$

$\because y(0) = 1 \Rightarrow 0 = \log_2 e + C$

$C = -\log_2 e$

$\Rightarrow \log_2(2^y - 1) = (2^x - 1) \log_2 e$

put $x = 1$, $\log_2(2^y - 1) = \log_2 e$

$2^y = e + 1$

$y = \log_2(e + 1)$ Ans.

17. $\lim_{x \rightarrow 0} \frac{\sin^2(\pi \cos^4 x)}{x^4}$ is equal to :

- (1) π^2 (2) $2\pi^2$
 (3) $4\pi^2$ (4) 4π

Official Ans. by NTA (3)

Sol. $\lim_{x \rightarrow 0} \frac{\sin^2(\pi \cos^4 x)}{x^4}$
 $\lim_{x \rightarrow 0} \frac{1 - \cos(2\pi \cos^4 x)}{2x^4}$
 $\lim_{x \rightarrow 0} \frac{1 - \cos(2\pi - 2\pi \cos^4 x)}{[2\pi(1 - \cos^4 x)]^2} \cdot 4\pi^2 \cdot \frac{\sin^4 x}{2x^4} (1 + \cos^2 x)^2$
 $= \frac{1}{2} \cdot 4\pi^2 \cdot \frac{1}{2} (2)^2 = 4\pi^2$

18. A vertical pole fixed to the horizontal ground is divided in the ratio 3 : 7 by a mark on it with lower part shorter than the upper part. If the two parts subtend equal angles at a point on the ground 18 m away from the base of the pole, then the height of the pole (in meters) is :

- (1) $12\sqrt{15}$ (2) $12\sqrt{10}$
 (3) $8\sqrt{10}$ (4) $6\sqrt{10}$

Official Ans. by NTA (2)

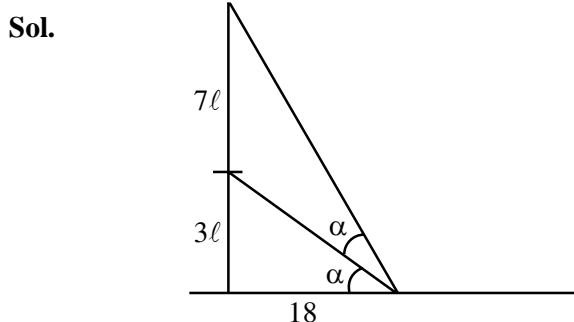

Let height of pole = $10l$

$$\tan \alpha = \frac{3l}{18} = \frac{l}{6}$$

$$\tan 2\alpha = \frac{10l}{18}$$

$$\frac{2 \tan \alpha}{1 - \tan^2 \alpha} = \frac{10l}{18}$$

$$\text{use } \tan \alpha = \frac{l}{6} \Rightarrow l = \sqrt{\frac{72}{5}}$$

$$\text{height of pole} = 10l = 12\sqrt{10}$$

19. If $a_r = \cos \frac{2r\pi}{9} + i \sin \frac{2r\pi}{9}$, $r = 1, 2, 3, \dots, i = \sqrt{-1}$,

then the determinant $\begin{vmatrix} a_1 & a_2 & a_3 \\ a_4 & a_5 & a_6 \\ a_7 & a_8 & a_9 \end{vmatrix}$ is equal to :

- (1) $a_2 a_6 - a_4 a_8$ (2) a_9
 (3) $a_1 a_9 - a_3 a_7$ (4) a_5

Official Ans. by NTA (3)

Sol. $a_r = e^{\frac{i2\pi r}{9}}$, $r = 1, 2, 3, \dots$ a_1, a_2, a_3, \dots are in G.P.

$$\begin{vmatrix} a_1 & a_2 & a_3 \\ a_4 & a_5 & a_6 \\ a_7 & a_8 & a_9 \end{vmatrix} = \begin{vmatrix} a_1 & a_1^2 & a_1^3 \\ a_1^4 & a_1^5 & a_1^6 \\ a_1^7 & a_1^8 & a_1^9 \end{vmatrix} = a_1 \cdot a_1^4 \cdot a_1^7 \begin{vmatrix} 1 & a_1 & a_1^2 \\ 1 & a_1 & a_1^2 \\ 1 & a_1 & a_1^2 \end{vmatrix} = 0$$

$$\text{Now } a_1 a_9 - a_3 a_7 = a_1^{10} - a_1^{10} = 0$$

20. The line $12x \cos \theta + 5y \sin \theta = 60$ is tangent to which of the following curves?

- (1) $x^2 + y^2 = 169$
 (2) $144x^2 + 25y^2 = 3600$
 (3) $25x^2 + 12y^2 = 3600$
 (4) $x^2 + y^2 = 60$

Official Ans. by NTA (2)

Sol. $12x \cos \theta + 5y \sin \theta = 60$

$$\frac{x \cos \theta}{5} + \frac{y \sin \theta}{12} = 1$$

$$\text{is tangent to } \frac{x^2}{25} + \frac{y^2}{144} = 1$$

$$144x^2 + 25y^2 = 3600$$

SECTION-B

1. Let $[t]$ denote the greatest integer $\leq t$. Then the

value of $8 \cdot \int_{-\frac{1}{2}}^1 ([2x] + |x|) dx$ is _____.

Official Ans. by NTA (5)

Sol. $I = \int_{-1/2}^1 ([2x] + |x|) dx$

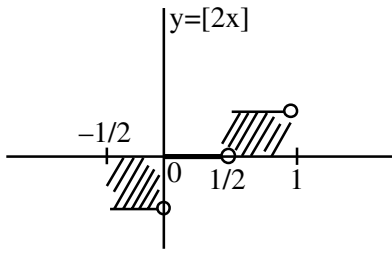

$$= \int_{-1/2}^0 [2x] dx + \int_{-1/2}^1 |x| dx$$

$$= 0 + \int_{-1/2}^0 (-x) dx + \int_0^1 x dx$$

$$= \left(-\frac{x^2}{2}\right)_{-1/2}^0 + \left(\frac{x^2}{2}\right)_0^1$$

$$= \left(0 + \frac{1}{8}\right) + \frac{1}{2}$$

$$= \frac{5}{8}$$

$8I = 5$

2. A point z moves in the complex plane such that

$\arg\left(\frac{z-2}{z+2}\right) = \frac{\pi}{4}$, then the minimum value of

$|z - 9\sqrt{2} - 2i|^2$ is equal to _____.

Official Ans. by NTA (98)

Sol. Let $z = x + iy$

$\arg\left(\frac{x-2+iy}{x+2+iy}\right) = \frac{\pi}{4}$

$\arg(x-2+iy) - \arg(x+2+iy) = \frac{\pi}{4}$

$\tan^{-1}\left(\frac{y}{x-2}\right) - \tan^{-1}\left(\frac{y}{x+2}\right) = \frac{\pi}{4}$

$\frac{\frac{y}{x-2} - \frac{y}{x+2}}{1 + \left(\frac{y}{x-2}\right)\left(\frac{y}{x+2}\right)} = \tan \frac{\pi}{4} = 1$

$\frac{xy + 2y - xy + 2y}{x^2 - 4 + y^2} = 1$

$4y = x^2 - 4 + y^2$

$x^2 + y^2 - 4y - 4 = 0$

locus is a circle with center $(0, 2)$ & radius $= 2\sqrt{2}$

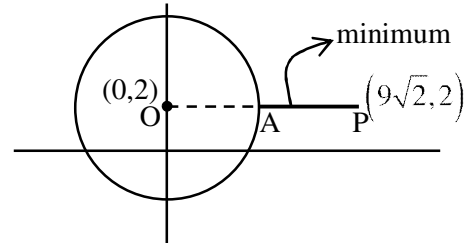

min. value $= (AP)^2 = (OP - OA)^2$

$= (9\sqrt{2} - 2\sqrt{2})^2$

$= (7\sqrt{2})^2 = 98$

3. The square of the distance of the point of intersection of the line $\frac{x-1}{2} = \frac{y-2}{3} = \frac{z+1}{6}$ and the plane $2x - y + z = 6$ from the point $(-1, -1, 2)$ is _____.

Official Ans. by NTA (61)

Sol. $\frac{x-1}{2} = \frac{y-2}{3} = \frac{z+1}{6} = \lambda$

$x = 2\lambda + 1, y = 3\lambda + 2, z = 6\lambda - 1$

for point of intersection of line & plane

$2(2\lambda + 1) - (3\lambda + 2) + (6\lambda - 1) = 6$

$7\lambda = 7 \Rightarrow \lambda = 1$

point : $(3, 5, 5)$

$(\text{distance})^2 = (3+1)^2 + (5+1)^2 + (5-2)^2$

$= 16 + 36 + 9 = 61$

4. If 'R' is the least value of 'a' such that the function $f(x) = x^2 + ax + 1$ is increasing on $[1, 2]$ and 'S' is the greatest value of 'a' such that the function $f(x) = x^2 + ax + 1$ is decreasing on $[1, 2]$, then the value of $|R - S|$ is _____.

Official Ans. by NTA (2)

Sol. $f(x) = x^2 + ax + 1$

$f'(x) = 2x + a$

when $f(x)$ is increasing on $[1, 2]$

$2x + a \geq 0 \quad \forall x \in [1, 2]$

$a \geq -2x \quad \forall x \in [1, 2]$

$R = -4$

when $f(x)$ is decreasing on $[1, 2]$

$2x + a \leq 0 \quad \forall x \in [1, 2]$

$a \leq -2 \quad \forall x \in [1, 2]$

$S = -2$

$|R - S| = |-4 + 2| = 2$

5. The mean of 10 numbers

$7 \times 8, 10 \times 10, 13 \times 12, 16 \times 14, \dots$ is _____.

Official Ans. by NTA (398)

Sol. $7 \times 8, 10 \times 10, 13 \times 12, 16 \times 14 \dots\dots$

$T_n = (3n + 4)(2n + 6) = 2(3n + 4)(n + 3)$

$= 2(3n^2 + 13n + 12) = 6n^2 + 26n + 24$

$S_{10} = \sum_{n=1}^{10} T_n = 6 \sum_{n=1}^{10} n^2 + 26 \sum_{n=1}^{10} n + 24 \sum_{n=1}^{10} 1$

$= \frac{6(10 \times 11 \times 21)}{6} + 26 \times \frac{10 \times 11}{2} + 24 \times 10$

$= 10 \times 11(21 + 13) + 240$

$= 3980$

Mean = $\frac{S_{10}}{10} = \frac{3980}{10} = 398$

6. If the variable line $3x + 4y = \alpha$ lies between the two circles $(x - 1)^2 + (y - 1)^2 = 1$ and $(x - 9)^2 + (y - 1)^2 = 4$, without intercepting a chord on either circle, then the sum of all the integral values of α is _____.

Official Ans. by NTA (165)

Sol.

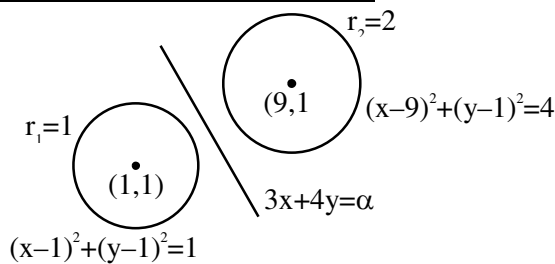

Both centres should lie on either side of the line as well as line can be tangent to circle.

$(3 + 4 - \alpha) \cdot (27 + 4 - \alpha) < 0$

$(7 - \alpha) \cdot (31 - \alpha) < 0 \Rightarrow \alpha \in (7, 31) \dots(1)$

d_1 = distance of (1, 1) from line

d_2 = distance of (9, 1) from line

$d_1 \geq r_1 \Rightarrow \frac{|7 - \alpha|}{5} \geq 1 \Rightarrow \alpha \in (-\infty, 2] \cup [12, \infty) \dots(2)$

$d_2 \geq r_2 \Rightarrow \frac{|31 - \alpha|}{5} \geq 2 \Rightarrow \alpha \in (-\infty, 21] \cup [41, \infty) \dots(3)$

$(1) \cap (2) \cap (3) \Rightarrow \alpha \in [12, 21]$

Sum of integers = 165

7. The number of six letter words (with or without meaning), formed using all the letters of the word 'VOWELS', so that all the consonants never come together, is _____.

Official Ans. by NTA (576)

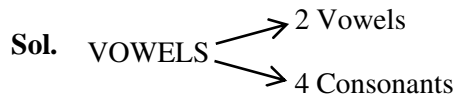

All Consonants should not be together

= Total - All consonants together,

= $6! - 3! 4! = 576$

8. If $x \phi(x) = \int_5^x (3t^2 - 2\phi'(t)) dt$, $x > -2$, and $\phi(0) = 4$, then $\phi(2)$ is _____.

Official Ans. by NTA (4)

Sol. $x\phi(x) = \int_5^x 3t^2 - 2\phi'(t) dt$

$$x\phi(x) = x^3 - 125 - 2[\phi(x) - \phi(5)]$$

$$x\phi(x) = x^3 - 125 - 2\phi(x) - 2\phi(5)$$

$$\phi(0) = 4 \Rightarrow \phi(5) = -\frac{133}{2}$$

$$\phi(x) = \frac{x^3 + 8}{x + 2}$$

$$\phi(2) = 4$$

- 9.** If $\left(\frac{3^6}{4^4}\right)k$ is the term, independent of x , in the binomial expansion of $\left(\frac{x}{4} - \frac{12}{x^2}\right)^{12}$, then k is equal to _____.

Official Ans. by NTA (55)

Sol. $\left(\frac{x}{4} - \frac{12}{x^2}\right)^{12}$

$$T_{r+1} = (-1)^r \cdot {}^{12}C_r \left(\frac{x}{4}\right)^{12-r} \left(\frac{12}{x^2}\right)^r$$

$$T_{r+1} = (-1)^r \cdot {}^{12}C_r \left(\frac{1}{4}\right)^{12-r} (12)^r \cdot (x)^{12-3r}$$

Term independent of $x \Rightarrow 12 - 3r = 0 \Rightarrow r = 4$

$$T_5 = (-1)^4 \cdot {}^{12}C_4 \left(\frac{1}{4}\right)^8 (12)^4 = \frac{3^6}{4^4} \cdot k$$

$$\Rightarrow k = 55$$

- 10.** An electric instrument consists of two units. Each unit must function independently for the instrument to operate. The probability that the first unit functions is 0.9 and that of the second unit is 0.8. The instrument is switched on and it fails to operate. If the probability that only the first unit failed and second unit is functioning is p , then $98p$ is equal to _____.

Official Ans. by NTA (28)

Sol. I_1 = first unit is functioning

I_2 = second unit is functioning

$$P(I_1) = 0.9, P(I_2) = 0.8$$

$$P(\bar{I}_1) = 0.1, P(\bar{I}_2) = 0.2$$

$$P = \frac{0.8 \times 0.1}{0.1 \times 0.2 + 0.9 \times 0.2 + 0.1 \times 0.8} = \frac{8}{28}$$

$$98P = \frac{8}{28} \times 98 = 28$$